



**Amended pursuant to Rule 6-1(1)(a)
of the Supreme Court Civil Rules**

Original filed April 11, 2023

NO. S232802
VANCOUVER REGISTRY

IN THE SUPREME COURT OF BRITISH COLUMBIA

BETWEEN:



PLAINTIFF

AND:

FCA CANADA INC. and
FCA US LLC

DEFENDANTS

Brought under the *Class Proceedings Act*, R.S.B.C. 1996, c.50

AMENDED NOTICE OF CIVIL CLAIM

This action has been started by the plaintiff(s) for the relief set out in Part 2 below. If you intend to respond to this action, you or your lawyer must

- (a) file a response to civil claim in Form 2 in the above-named registry of this court within the time for response to civil claim described below, and
- (b) serve a copy of the filed response to civil claim on the plaintiff.

If you intend to make a counterclaim, you or your lawyer must

- (a) file a response to civil claim in Form 2 and a counterclaim in Form 3 in the above-named registry of this court within the time for response to civil claim described below, and
- (b) serve a copy of the filed response to civil claim and counterclaim on the plaintiff and on any new parties named in the counterclaim.

JUDGMENT MAY BE PRONOUNCED AGAINST YOU IF YOU FAIL to file the response to civil claim within the time for response to civil claim described below.

TIME FOR RESPONSE TO CIVIL CLAIM

A response to civil claim must be filed and served on the plaintiff(s),

- (a) if you reside anywhere in Canada, within 21 days after the date on which a copy of the filed notice of civil claim was served on you,
- (b) if you reside in the United States of America, within 35 days after the date on which a copy of the filed notice of civil claim was served on you,
- (c) if you reside elsewhere, within 49 days after the date on which a copy of the filed notice of civil claim was served on you, or
- (d) if the time for response to civil claim has been set by order of the court, within that time.

CLAIM OF THE PLAINTIFF(S)

Part 1: STATEMENT OF FACTS

A. Introduction - Nature of Claim

1. The within proposed consumer product liability multi-jurisdictional class proceeding involves 2014-2020 Jeep Grand Cherokee, 2021-2023 Jeep Wrangler and Gladiator, 2014-2019 and 2022-2023 and Dodge RAM 1500 diesel vehicles designed, manufactured, assembled, tested, marketed, distributed, supplied, leased and/or sold by the Defendants, FCA CANADA INC. and FCA US LLC, in Canada, including the Province of British Columbia, equipped with a 3.0L EcoDiesel engine with a defective high-pressure fuel injection pump (“Affected Class Vehicles”) incompatible with the lubricity of North American diesel fuel specifications designed by Robert Bosch GmbH (the “CP4 fuel pump”). The CP4 fuel pump has a fragile and unstable design, which causes metal parts to rub against each other such that the friction generates metal shavings that contaminate the fuel system, resulting in the fuel injectors to become blocked and leading to catastrophic engine failure (“Fuel Pump Defect”). The Defendants, FCA CANADA INC. and FCA US LLC, failed to disclose this critical defect to consumers.
2. The Defendant, FCA CANADA INC. and FCA US LLC, promote their EcoDiesel technology as the best of both worlds: a “green” alternative to gasoline with reduced emissions coupled with diesel’s benefits of greater torque, power, and fuel efficiency. The

Defendants, FCA CANADA INC. and FCA US LLC, then charge a premium for these EcoDiesel vehicles, selling them for thousands of dollars more than the cost of comparable gasoline vehicles. However, the Defendants, FCA CANADA INC. and FCA US LLC, were aware that Bosch's CP4 fuel pump design has never been compatible with North American diesel fuel standards. The CP4 fuel pump's fragile design is not built to withstand North American diesel fuel specifications in terms of lubrication or water content. The CP4 fuel pump uses the fuel itself for lubrication, and the design of the pump requires a cam and two pumping cylinders with individual rollers designed to seamlessly roll together without skipping, sliding, sticking, or wearing in order for it to operate effectively. If the fuel used with the CP4 fuel pump is not sufficiently lubricious—which most North American diesel is not—the cam and rollers wear against each other and generate tiny metal shavings that disperse throughout the high-pressure fuel injection system.

3. The release of these metal shavings into the fuel system is catastrophic, as it causes the fuel injectors to become blocked and leads to an entire shutdown of the engine. Repair costs for a catastrophic failure are at least \$10,000 and are time-intensive; however, any such repair is futile because it will not actually fix the issue so long as the vehicle is being filled with North American diesel fuel. Further, after a CP4 fuel pump failure occurs the Defendants', FCA CANADA INC.'s and FCA US LLC's, recall remedy is to simply replace the CP4 fuel pump with another defective CP4 fuel pump with the same basic fragile design with the same propensity for failure in the future. The recall remedy is an inadequate fix and does not remedy the Fuel Pump Defect or fully reimburse the Plaintiff and putative class members for damages in the form of out-of-pocket costs of repair, including catastrophic failure and replacement of fuel system, engine component parts and/or the engine itself. The recall remedy does not remove the Fuel Pump Defect or reimburse the Plaintiff and putative Class Members of all out-of-pocket costs of repair.

4. Catastrophic failure can occur as early as kilometer one, as the fuel injection disintegration process begins at the very first fill of the fuel tank and start of the engine, with fuel pump components beginning to deteriorate and dispersing metal shavings throughout the internal engine components and fuel supply system. Further, catastrophic failure often causes the vehicle to shut off while in motion and renders it unable to be

restarted, because the vehicle's fuel injection system and engine component parts have been completely contaminated with metal shards. The sudden and unexpected shutoff of the vehicle's engine while it is in motion (and subsequent inability to restart the vehicle) poses a real and substantial danger to drivers and vehicle occupants of the Affected Class Vehicles.

5. Even short of catastrophic failure, the fragile fuel pump design can lead to fuel pump component wear that will damage the fuel injectors, or cause them to inject fuel at times and rates which causes significant damage to the component parts of the vehicle's engine. There are numerous ways in which the defective fuel pump can damage the engine and related components, including: (1) over-fueling, which decreases fuel economy; (2) broken injector tips; (3) fuel spray hitting the cylinder wall, causing dilution of the lube oil, which damages the engine; (4) over-heating of cylinders causing wear damage to the cylinders; (5) melted or twisted pistons; (6) damaged exhaust valves; (7) damaged turbochargers; (8) hydraulic lock; (9) damaged cylinder heads; (10) damaged exhaust manifolds; and (11) damage and/or loss of emission control (including increases in NOx, particulates, and carbon dioxide).
6. The Defendants', FCA CANADA INC.'s and FCA US LLC's, frequent company line is to blame catastrophic failures on "contaminated fuel," which is not covered under warranty because it is "not caused by" the Defendants, FCA CANADA INC. and/or FCA US LLC. The Defendants', FCA CANADA INC.'s and FCA US LLC's, reliance on the "poor fuel quality" defense is problematic, however, because it is basically impossible for consumers to determine the quality of their fuel when they fill up at the pump—and one "bad" fueling can lead to catastrophic failure. Consumers have no way to assess the quality of the fuel they purchase or to confirm if a fuel complies with the applicable regulatory requirements.
7. The Fuel Pump Defect is especially impactful on consumers as the Affected Class Vehicles range in price from approximately \$50,000 to \$100,000. Diesel vehicle owners pay a premium for their vehicles because diesel engines are traditionally expected to last for a range of 800,000–1,300,000 kilometers.
8. The decision to use the CP4 fuel pump in the Affected Class Vehicles is particularly

egregious here because the defective design of the fuel pump has been known for many years by the automotive industry—dating back at least a decade. Well before the Defendants, FCA, CANADA INC. and FCA US LLC, chose to use the CP4 fuel pump, the issue of North American diesel fuel consistency and lubrication was well-known throughout the automobile manufacturing industry, but nonetheless was totally disregarded in the respective design, manufacture, marketing, and sales and/or leases of the Affected Class Vehicles. The Defendants, FCA CANADA INC. and FCA US LLC, as well as other automotive manufacturers, such as Ford and General Motors, had industry-wide experience with catastrophic fuel injection pump failures when cleaner diesel standards were first implemented in the 1990s. By 2002, the Truck & Engine Manufacturers Association (“EMA”)—of which the Defendants, FCA CANADA INC. and/or FCA US LLC, are standing members—acknowledged that the lower lubricity of North American diesel could cause catastrophic failure in high-pressure fuel injection system components that are made to European diesel specifications (which require more lubricious fuel). ~~As such, the Defendants, FCA CANADA INC. and FCA US LLC, abandoned the CP4 fuel pump for their post-2020 model year diesel engine vehicles, including the 3.0L EcoDiesel engine.~~

9. The Defendants, FCA CANADA INC. and/ FCA US LLC, were fully aware of the defective fuel pump based on similar litigation against the Defendant, FCA US LLC, in the United States related to the same fuel pump in 2014-present FCA EcoDiesel pickup trucks. Notwithstanding such notice, the Defendants, FCA CANADA INC. and FCA US LLC, continued to develop, manufacture, and sell the Affected Class Vehicles with the defective fuel pump, knowing the huge expense that consumers would have to incur to repair and replace the defective CP4 fuel pump.
10. As a result of this alleged misconduct, the Plaintiff and putative class members were harmed and suffered actual damages. The Plaintiff and putative class members did not receive the benefit of their bargain; rather, they purchased and/or leased vehicles that are of a lesser standard, grade and quality than represented, and they did not receive vehicles that met ordinary and reasonable consumer expectations regarding safe and reliable operation. Purchasers and/or lessees of the Affected Class Vehicles paid more, either through a higher purchase price or lease payments, than they would have had the

Fuel Pump Defect been disclosed. The Plaintiff and putative class members were deprived of having a safe, defect-free fuel pump installed in their vehicles, and the Defendants, FCA CANADA INC. and FCA US LLC, have unjustly benefitted from the higher price paid by consumers for such diesel vehicles.

11. The Plaintiff and putative class members also suffered damages in the form of out-of-pocket costs of repair, including catastrophic failure and replacement of fuel system or engine component parts, decreased performance of the Affected Class Vehicles, diminished value of the Affected Class Vehicles and increased fuel costs.
12. No reasonable consumer would have purchased and/or leased an Affected Class Vehicle had the Defendants, FCA CANADA INC. and FCA US LLC, made full disclosure of the Fuel Pump Defect, or would have paid a lesser price.
13. The Plaintiff and putative class members expected that the Defendants, FCA CANADA INC. and FCA US LLC, would disclose material facts about the durability, fuel economy, and longevity of their Affected Class Vehicles and the existence of any defect that will result in expensive and non-ordinary repairs. The Defendants, FCA CANADA INC. and FCA US LLC, failed to do so.
14. The Plaintiff seeks relief for all other owners and/or lessees of the Affected Class Vehicles equipped with the 3.0L EcoDiesel engine with the defective CP4 fuel pump, including, *inter alia*, recovery of damages and/or repair under provincial consumer protection legislation, breach of express warranty, breach of implied warranty of merchantability and reimbursement of all expenses associated with the repair and/or recall of the Fuel Pump Defect in the Affected Class Vehicles.

B. The Parties

Representative Plaintiff

15. The Plaintiff [REDACTED] has an address for service c/o 405 - 4603 Kingsway, Burnaby, British Columbia, Canada, V4H 4M4.

16. On or about December 18, 2019 the Plaintiff purchased a 2015 Jeep Grand Cherokee (“Jeep Grand Cherokee”) equipped with a 3.0L EcoDiesel engine with the CP4 fuel pump, an Affected Class Vehicle, primarily for personal, family or household use, from a private dealership, located in Langley, British Columbia, Canada for \$40,486.01, inclusive of tax. The purchase price included an extended warranty at a cost of \$2,450.00.
17. At the time of the Plaintiff’s purchase the Jeep Grand Cherokee had 81,750 kilometers on it.
18. In or about August 2019 the Jeep Grand Cherokee shut off or stalled while in motion on the highway as it was being driven by its prior owner and would not subsequently start. The 3.0L EcoDiesel engine was replaced as metal shards were found in the oil pan. At the time the Jeep Grand Cherokee had 79,930 kilometers on it.
19. In or about November 2020 the Jeep Grand Cherokee stalled while in motion and would not start. The Plaintiff noticed an excessive noise coming from the fuel pump area. The Plaintiff took her Jeep Grand Cherokee to a Chrysler dealership which upon a diagnostic inspection found that the CP4 fuel pump was contaminated with metal particles, debris or shavings. There was extensive damage to, and contamination of, the vehicle’s entire high-pressure fuel system, which required, *inter alia*, replacement of the CP4 fuel pump, fuel rails, lines, injectors and filter and draining and cleaning of the fuel tank. The cost of such high-pressure fuel system repairs was \$11,737.19. At the time of the catastrophic failure of the defective CP4 fuel pump the Jeep Grand Cherokee had 99,189 kilometers on it.
20. In or about March 2021 the Plaintiff while operating the Jeep Grand Cherokee began to notice a change in engine performance as the vehicle would not accelerate when she pressed on the accelerator pedal. The Plaintiff took her Jeep Grand Cherokee to a Chrysler dealership which upon a diagnostic inspection found that the powertrain control module needed to be reset. Further, the diagnostic inspection found that the Jeep Grand Cherokee required replacement of the exhaust gas recirculation (“EGR”) cooler pursuant to an outstanding recall notice but no replacement part was available. At the time the Jeep Grand Cherokee had 106,545 kilometers on it.

21. In or about April 2022 the check engine light of the Jeep Grand Cherokee came on. The the Plaintiff took her Jeep Grand Cherokee to a Chrysler dealership which upon a diagnostic inspection found that the diesel exhaust filter injector needed to be replaced along with the EGR cooler. The cost of such repairs was \$931.67. At the time the Jeep Grand Cherokee had 133,880 kilometers on it.

22. In or about February 2023 the Jeep Grand Cherokee shut off or stalled while in motion and the oil pressure low light came on as result of the Fuel Pump Defect. The Plaintiff took her Jeep Grand Cherokee to an automotive repair shop which upon a diagnostic inspection found that the oil filter, oil pan and oil pump screen were extensively contaminated with metal particles, debris or shavings. As a result thereof, the Jeep Grand Cherokee required a new diesel engine at a cost of \$29,303.00, inclusive of tax. At the time of the catastrophic failure of the vehicle's high-pressure fuel system, the Jeep Grand Cherokee had 156,021 kilometers on it.

23. Prior to purchasing the Affected Class Vehicle, Plaintiff had been looking for an sport utility vehicle ("SUV") that was durable, powerful, reliable, and could obtain the high kilometers per gallon of a diesel vehicle. In contemplating her needs, including the need to purchase a vehicle fit for daily use, Plaintiff saw and recalled the Defendants', FCA CANADA INC.'s and/or FCA US LLC's, television commercials, radio advertisements, and printed brochures and advertisements wherein the Defendants, FCA CANADA INC. and/or FCA US LLC, claimed the diesel-fueled Jeep Grand Cherokee—the Affected Class Vehicle Plaintiff would subsequently purchase—had greater fuel economy, superior horsepower, more environmentally friendly emissions, and enhanced durability compared to other comparable SUVs on the market. In addition, none of the advertisements reviewed or representations received by Plaintiff contained any disclosure that the Jeep Grand Cherokee equipped with the 3.0L EcoDiesel engine had a defective fuel pump which would lead to wear on the components and lead to catastrophic failure. Had the Defendants, FCA CANADA INC. and FCA US LLC, made this disclosure, she would not have purchased the her Jeep Grand Cherokee or would have paid less for it.

24. There is a substantial difference in the market value of the vehicle promised by the Defendants, FCA CANADA INC. and FCA US LLC, and the market value of the vehicle

received by Plaintiff. Therefore, Plaintiff did not receive the benefit of the bargain.

25. The Plaintiff also paid a premium for her Jeep Grand Cherokee. The Plaintiff knew that diesel vehicles were more expensive than a gas vehicles, but she purchased the Jeep Grand Cherokee based on her belief that it would be more durable compared to a gas engine, with superior torque and fuel efficiency. The premium for a diesel vehicle compared to a gasoline equivalent is approximately \$5,000-\$8,000. The Plaintiff accordingly overpaid for her Jeep Grand Cherokee by at least the value of this premium.

The Defendants

FCA CANADA INC. and FCA US LLC

26. The Defendant, FCA CANADA INC., is a company duly incorporated pursuant to the laws of Canada, registered within the Province of British Columbia under number A0004330, and has an attorney, Donald M. Dalik, at #2900 - 550 Burrard Street, Vancouver, British Columbia, V6C 0A3, Canada.
27. The Defendant, FCA US LLC, is a company duly incorporated pursuant to the laws of the State of Delaware, one of the United States of America, and has a registered agent, the Corporation Trust Company, at Corporation Trust Center, 1209 Orange Street, Wilmington, Delaware, 19801, United States of America.
28. At all material times to the cause of action herein, the Defendant, FCA CANADA INC., was, and is, a wholly owned subsidiary of the Defendant, FCA US LLC, which, *inter alia*, designs, manufacturers, tests, assembles, markets, distributes, supplies and/or sells Jeep Grand Cherokee, Jeep Wrangler, Jeep Gladiator and Dodge RAM 1500 diesel vehicles, including the Affected Class Vehicles as averred to herein, equipped with a 3.0L EcoDiesel engine with a defective CP4 fuel pump.
29. At all material times to the cause of action herein, the Defendant, FCA CANADA INC., designs, manufactures, tests and/or assembles Jeep Grand Cherokee, Jeep Wrangler, Jeep Gladiator and Dodge RAM 1500 diesel vehicles, including the Affected Class

Vehicles as averred to herein, equipped with a 3.0L EcoDiesel engine with a defective CP4 fuel pump, in Canada at an automobile plant located in the Province of Ontario for distribution and/or sale in Canada and/or the United States of America.

30. At all material times to the cause of action herein, the Defendant, FCA US LLC, is an American automobile manufacturer which, *inter alia*, designs, manufactures, tests and/or assembles Jeep Grand Cherokee, Jeep Wrangler, Jeep Gladiator and Dodge RAM 1500 diesel vehicles, including the Affected Class Vehicles as averred to in herein, equipped with a 3.0L Ecodiesel engine with a defective CP4 fuel pump, at automobile plants located, *inter alia*, in the States of Michigan and/or Ohio, for distribution and/or sale in the United States of America and Canada, including the Province of British Columbia.
31. At all material times to the cause of action herein, the Defendants, FCA CANADA INC. and FCA US LLC, shared the common purpose of, *inter alia*, developing, manufacturing, testing, assembling, marketing, distributing, supplying, selling and/or distributing the Affected Class Vehicles as averred to in herein, equipped with a 3.0L Ecodiesel engine with a defective CP4 fuel pump in Canada and within the Province of British Columbia. Further, the business and interests of the Defendants, FCA CANADA INC. and FCA US LLC, are inextricably interwoven with that of the other as to the Fuel Pump Defect in the Affected Class Vehicles as averred to herein, such that each is the agent of the other.
32. Hereinafter, the Defendants, FCA CANADA INC. and FCA US LLC, are collectively referred to, and interchangeably, as the "Defendant, FCA", or "Defendants", unless referred to individually.
33. FCA-authorized automobile dealerships act as the Defendant's, FCA's, agents in selling automobiles under the Defendant, FCA, name and disseminating vehicle information provided by the Defendant, FCA, to consumers. At all relevant times, the Defendant's, FCA's, dealerships served as its agents for vehicle repairs and warranty issues because they performed repairs, replacements, and adjustments covered by the Defendant's, FCA's, manufacturer warranty pursuant to the contracts between the Defendant, FCA, and its authorized dealerships across North America, including the Province of British Columbia.

C. The Class

34. This action is brought on behalf of members of a class consisting of the Plaintiff, all British Columbia residents, and all other persons resident in Canada, ~~excluding the Province of Quebec,~~ who own, owned, lease and/or leased an Affected Class Vehicle (“Class” or “Class Members”), excluding employees, officers, directors, agents of the Defendants and their family members, class counsel, presiding judges and any person who has commenced an individual proceeding against or delivered a release to the Defendants concerning the subject of this proceeding, or such other class definition or class period as the Court may ultimately decide on the application for certification.

D. Factual Allegations

i. The Affected Class Vehicles contain CP4 fuel pump equipped EcoDiesel engines

35. For the purposes of this Amended Notice of Civil Claim, the “Affected Class Vehicles” consist of Defendant, FCA, manufactured diesel-fueled vehicles equipped with a 3.0L EcoDiesel engine, ranging from 2014-2020 model years of Jeep Grand Cherokee SUVs, 2021-2023 Jeep Wranglers and Gladiators and 2014-2019 and 2022-2023 Dodge RAM 1500 pick-up trucks. All vehicles falling under this Affected Class Vehicle group were manufactured with the defective CP4 fuel pump.

ii. National Highway Traffic and Safety Administration and Transport Canada recall Affected Class Vehicles as a result of safety concerns

36. On June 9, 2022 the National Highway Traffic and Safety Administration (“NHTSA”), the government vehicle safety regulator in the United States, approved a safety recall of 138,645 Affected Class Vehicles (22V-406). The NHTSA 573 Safety Recall Report states the following:

Some 2014-2020 MY Jeep Grand Cherokee vehicles equipped with a 3.0L diesel engine may have been built with a high pressure fuel pump (“HPFP”) that could fail prematurely.

Some 2014-~~2016~~ 2019 MY Ram 1500 vehicles equipped with a 3.0L diesel engine may have been built with a HPFP that could fail prematurely.

37. Under the header “Description of Defect,” the NHTSA 573 Safety Recall Report states the following:

A HPFP failure may introduce internally failed component debris into the fuel system causing fuel starvation.

38. The NHTSA 573 Safety Recall Report described the safety risk as follows:

Fuel starvation may result in an unexpected loss of motive power, which can cause a vehicle to crash without warning.

39. As to identification of any warning that can occur, the NHTSA 573 Safety Recall Report states that vehicle occupants may notice a malfunction indicator lamp, service electronic throttle indicator, a fuel leak at the HPFP or excessive noise from the HPFP. The proposed remedy is a HPFP with improved durability. FCA-authorized automobile dealerships were advised that the NHTSA recall was estimated to start in the first quarter of 2023 and further, that a stop-sale was in effect for the Affected Class Vehicles and a violation of this requirement by a dealer could result in a civil penalty of up to \$21,000 USD per vehicle.

40. The chronology section of the NHTSA 573 Safety Recall Report states that the Defendant, FCA, had determined that the CP4 fuel pump was the origin of Affected Class Vehicles stalling and further, as of May 18, 2022 it was aware of 215 customer assistance records, 1,061 warranty claims and three field reports regarding the defective CP4 fuel pump in Affected Class Vehicles. At the time of this recall no remedy was available and did not become available until December 2023 for the Ram 1500 and

January 2024 for the Jeep Grand Cherokee vehicles, and which remedy did not adequately or sufficiently fix the Fuel Pump Defect or fully reimburse putative Class Members out-of-pocket costs of repair, including catastrophic failure and replacement of fuel system, engine component parts and/or the engine caused by or resulting from the Fuel Pump Defect.

41. On June 9, 2022 Transport Canada issued a substantially similar recall of 55,711 Affected Class Vehicles (#2022-303) with the defective CP4 fuel pump. The Transport Canada recall states the following:

Issue:

On certain vehicles equipped with a 3.0L diesel engine, the high-pressure fuel pump could fail. If this happens, you may notice a change in engine performance, a fuel leak, or a malfunction indicator lamp and/or service electronic throttle control tell-tale may turn on. This could also result in a sudden loss of engine power while driving.

Safety Risk:

A sudden loss of engine power could increase the risk of a crash.

Corrective Actions:

FCA Canada will notify owners by mail and instruct you to take your vehicle to a dealership to replace the high-pressure fuel pump. Additional fuel system parts may be replaced, if necessary.

42. On April 13, 2023 NHTSA approved a safety recall of 45,711 Affected Class Vehicles (23V-263). The NHTSA 573 Safety Recall Report states the following:

Some 2021-2023 MY Jeep Wrangler vehicles equipped with a 3.0L diesel engine may have been built with a high pressure fuel pump (“HPFP”) that could fail prematurely.

Some 2021-2023 MY Jeep Gladiator vehicles equipped with a 3.0L diesel engine may have been built with a high pressure fuel pump (“HPFP”) that could fail prematurely.

Some 2022-2023 MY Ram 1500 vehicles equipped with a 3.0L diesel engine may have been built with a HPFP that could fail prematurely.

43. Under the header “Description of Defect,” the NHTSA 573 Safety Recall Report states the following:

A HPFP failure may introduce internally failed component debris into the fuel system causing fuel starvation.

44. The NHTSA 573 Safety Recall Report described the safety risk as follows:

Fuel starvation may result in an unexpected loss of motive power, which can cause a vehicle to crash without warning.

45. On April 13, 2023 Transport Canada issued a substantially similar recall of 4,112 Affected Class Vehicles (#2023-218) with the defective CP4 fuel pump. The Transport Canada recall states the following:

Issue:

On certain vehicles equipped with a 3.0L diesel engine, the high-pressure fuel pump could fail. If this happens, you may notice a change in engine performance, a fuel leak, or a malfunction indicator lamp and/or service electronic throttle control tell-tale may turn on. This could also result in a sudden loss of engine power while driving.

Safety Risk:

A sudden loss of engine power could increase the risk of a crash.

Corrective Actions:

FCA Canada will notify owners by mail and instruct you to take your vehicle to a dealership to replace the high-pressure fuel pump. Additional fuel system parts may be replaced, if necessary.

46. Despite issuing the above vehicle manufacturer recalls putative Class Members were routinely being denied a fix, repair and/or replacement due to fuel pump and fuel component part availability. Further, putative Class Members were not fully reimbursed out-of-pocket costs of repair, including catastrophic failure and replacement of fuel system, engine component parts and the engine caused by or resulting from the Fuel Pump Defect.

47. Even where the replacement fuel pump and fuel component parts are available for the recall remedies implemented by the Defendant, FCA, pursuant to the above averred Transport Canada recalls #2022-303 and #2023-218, these recall remedies do not adequately and sufficiently address the Fuel Pump Defect. The replacement CP4 fuel pump continues to be incompatible with the lubricity of North American diesel fuel specifications due to its fragile and unstable design which causes metal parts to rub up against each other such that the friction generates metal shavings that contaminate the fuel system, resulting in the fuel injectors to become blocked and leading to catastrophic engine failure. The replacement CP4 fuel pump is equally defective as the original equipped CP4 fuel pump in the Affected Class Vehicles. The Defendant, FCA's, remedy component of a replacement high pressure fuel pump with improved durability as failed to adequately fix the Fuel Pump Defect as owners and/or lessees of the Affected Class Vehicles continue experience the Fuel Pump Defect after receiving the recall remedy. The recall remedy does not remove the Fuel Pump Defect or reimburse the Plaintiff and putative Class Members of all out-of-pocket costs of repair.

iii. The Defendant, FCA, profits from the rise of diesel vehicles in North America

42-48. Diesel engines have long enjoyed a loyal following in some North American market segments because of their reliability, fuel efficiency, and power. Diesel engines produce

higher torque, even at low revolutions per minute (“RPM”), making them popular in buses, heavy-duty pickups, and vans, including commercial vehicles, farm trucks, and ambulances.

~~43.49.~~ The key benefits of diesel engines over their gasoline counterparts are the following:

(a) Durability: Diesel (compression ignition) engines are, by design, stronger and more robust than gasoline (spark ignition) engines, and their long life and low maintenance are among the reasons for their popularity.

(b) Fuel Efficiency: The diesel engine is 20-35% more efficient than a gasoline engine, because the compression ignition cycle (and greater compression ratio) is more thermodynamically efficient than the spark ignition cycle, and because diesel fuel has a greater energy content on a per gallon basis than gasoline. As a result, a diesel engine’s fuel cost per mile is expected to be lower than gasoline.

(c) Torque and Power: Diesel engines provide more torque, especially at low engine speeds, which leads to better acceleration and higher towing capacity. Modern diesel engines operating at higher speed can now match or exceed gasoline engines in terms of peak power. This combination of torque and power is another reason why some customers prefer diesel.

~~44.50.~~ Most Dodge RAM 1500-3500 series pickup trucks, as well as certain SUVs sold by the “Big Three Automakers” (FCA, Ford and GM)-including the Affected Class Vehicles at issue in this proposed class proceeding-offer both a gasoline and diesel option. Due to the features and advantages listed above, consumers are willing to pay a premium of \$5,000-\$8,000 for the diesel powered version.

~~45.51.~~ The diesel combustion process, invented by Rudolph Diesel over a century ago, uses a hydrocarbon-based fuel which is substantially different than gasoline. Diesel fuel is a heavier and less refined mix of hydrocarbons and is designed to self-ignite when mixed with air under elevated temperatures and pressures. In the diesel combustion process,

the fuel is pumped to a very high pressure and then forced into an injector through very small spray holes. This fuel is atomized into spray plumes of fine droplets in the engine combustion chamber. The droplets rapidly evaporate and mix with heated air and spontaneously ignite, thus releasing the energy to drive the piston and pressurize the fuel.

46.52. Since the invention and early development of the diesel engine more than 100 years ago, the injection of fuel into the cylinder has been one of its greatest technical challenges. Earlier versions of the fuel injection system were designed as a pump-line-nozzle arrangement where a fuel pump delivered fuel directly to each injector via its own fuel line. As emission and fuel economy standards have become more stringent, and customer demands for performance have increased, diesel manufacturers switched to a high-pressure, common rail system, starting in Europe in the 1990s.

47.53. In a common rail fuel system, a high-pressure pump supplies fuel to a reservoir (a pressure containment vessel) known as the fuel rail. The rail holds an ample supply of pressurized fuel available to be injected (or "metered") into the engine power cylinders by the fuel injectors. The flow of fuel in each injector is managed by a complex electronic control system, which is programmed by sophisticated algorithms and calibration files. The key advancement with the common rail system is that each injector is capable of injecting in multiple precise pulses of fuel and at varying times based on driving conditions.

48.54. The most complex and expensive part of the common rail fuel injection system are the high-pressure components, including the high-pressure fuel pump, the fuel rails, and the injectors.

49.55. One of the key benefits of common rail technology is the ability to have multiple fuel injection events in a single injection cycle. Multiple injections, executed by lifting the injector nozzle needle, are used to carefully meter fuel into the cylinder which smooths out the combustion event resulting in lower noise and lower emissions. The injectors spray an exceedingly fine mist of diesel fuel into the cylinder, where it ignites and powers the engine. The finer the mist, the less emissions, because the combustion process is more homogenous, which has at least two beneficial effects: (1) the smaller droplets evaporate

and mix more readily with the air, preventing the development of fuel-rich “pockets” which product particulate matter; and (2) homogenized levels of heat mean there are fewer high peak temperatures, which lead to formation of NOx. The net effect of the high-pressure system is less NOx and particular matter. Modern engines may have multiple injection events, including post injection of fuel used to release fuel into the exhaust stream for the purpose of heating up the after-treatment components to reduce emissions.

~~50-56.~~ In sum, the key benefits of modern common rail fuel system are, among others:

- Providing pressurized fuel to well above 2,000 bar across most of the operating range of the engine (previous mechanical fuel systems could only achieve high pressure at high engine speeds):

- Multiple injection events, accurately timed and measured for the precise engine operating conditions to meet stringent noise and emissions regulations, including the following:
 - o Cold-start ability can be improved by early pre-injections to avoid the need for glow plugs.

 - o Engine noise can be lowered by pre-injections of fuel prior to main injection to produce power.

 - o After-treatment systems (particulate filters) can be regenerated by very late post injections.

 - o Injection rates can be digitally “shaped” to give an optimum rate of injected fuel to better control the diesel heat release rate, which minimizes NOx emissions.

 - o Exhaust particulates can also be lowered by injection “post” or late small amounts of fuel.

- High reliability and durability – common rail systems in Europe have been shown to be more reliable and durable than previous mechanical fuel systems if properly fueled and maintained.
- Less maintenance– modern common rail systems are designed to be self-adapting and require little maintenance.
- Less noise, vibration and handling problems–precise control over the injection and combustion events reduces engine noise, runs more quietly, produces less shaking and shock, and produces better operator control over the acceleration of the vehicle. High pressures are only generated in the centralized fuel pump rather than in individual mechanical injectors, which reduces engine vibration and gear train torques and noises.
- Higher injection pressure–pressures up to 2,500 bar (36,000 pounds per square inch) are only achievable with common rail fuel systems. The higher pressures are necessary for improved fuel atomization and more complete combustion.
- Better engine combustion management – the precision control offered by common rail reduces the mechanical strains on the engine, including peak cylinder pressures, temperatures, and observing exhaust after-treatment system limits.

51-57. From the outset, the Defendant, FCA, was in competition with fellow Big Three Automakers, each racing to dominate the growing North American diesel vehicle market. The Defendant, FCA, looked to international automotive parts supplier Bosch to increase the fuel efficiency and power of its diesel engines. The heart of this diesel revolution would be powered by Bosch's more durable CP3 fuel pump, the predecessor to the CP4 fuel pump at issue in within proposed class proceeding. The reliability of the CP3 fuel pump became key to the "million-mile" performance reputation of diesel truck engines in North America.

52-58. North American consumers paid a premium for the increased reliability, fuel efficiency, and power of diesel. The CP4 fuel pump would purportedly maintain reliability while also increasing fuel efficiency and power. The over-simplified design of the CP4 fuel pump

rendered it cheaper to manufacture, but also increased its need for high lubricity fuel, and increased the likelihood that the ultimate failure would be catastrophic.

iv. The fragile CP4 fuel pump design

53-59. The Bosch CP4 fuel pump is directly coupled to the engine, which means it is operating whenever the engine is operating. Since the CP4 pump is a critical part of the engine system it must be designed for very long life and must be capable of operating with commercially available fuel. A sound and robust design would also make it tolerant to fuels that are commercially sold, but do not meet the proper requirements. It should also be designed to withstand some level of customer abuse and neglect, such as inadvertent misfueling, running out of fuel, delaying a filter change, or draining the water separator.

54-60. The CP4 fuel pump operates at higher pressures than its predecessor, the CP3 fuel pump, and has inherently higher Hertz contact stresses than the CP3 fuel pump, which exacerbates the wearing of the pump parts. The CP3 fuel pump has three pumping cylinders and plungers. As the camshaft rotates, the polygon is moved in a sliding manner against the plunger foot plate and converting rotational (circular) motion into linear (up and down) motion. Below is a diagram of the CP3 fuel pump:

Figure 1: CP3 Fuel Pump

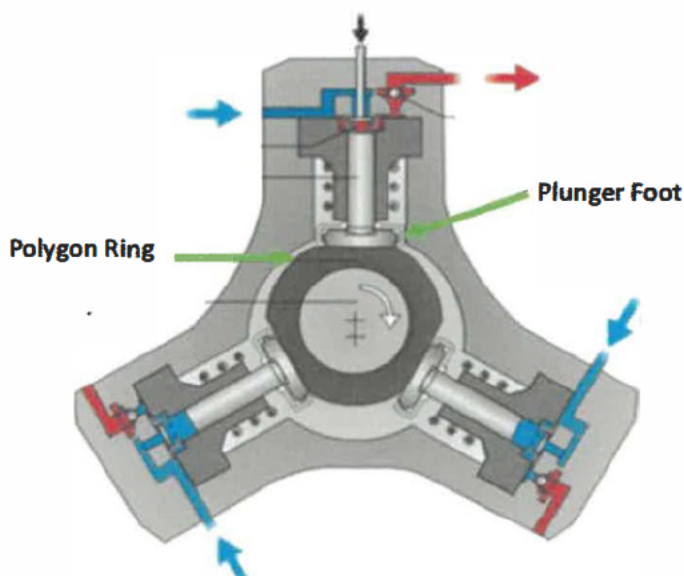

- 55-61. Due to its sliding foot contact area and lower stresses, the CP3 fuel pump is more tolerant of poor quality fuel, i.e., fuel that is less lubricious.
- 56-62. The CP4 fuel pump design was a radical departure from the CP3 fuel pump, and it relies on a fragile cam-roller-tappet mechanism which did not exist in the CP3 fuel pump. Instead of the wide plunger foot plates sliding against the wide polygon cam to drive the plungers (as shown in Figure 1 above), the CP4 fuel pump uses a small, 10 mm roller pin (about the size of a AAA battery) as the only source of contact with the camshaft. With this system, the CP4 fuel pump system is placing a lot of pressure on the contact point between the roller and the cam. This very small area of contact carries all the forces required to transfer the energy to generate the very high pumping pressures. In addition, since the 10 mm diameter roller is about one quarter the size of the camshaft lobe on which it rotates, the smaller roller must rotate four times as fast as the CP4 fuel pump camshaft. Since the Power Stroke engine drives the CP4 fuel pump at the same speed as the engine, this means the roller must rotate at four times the engine pump speed, or in the range of 11,200 revolutions per minute (for an engine speed of 2,800 rpm). Below is a schematic of the tappet holding the roller pin, which contacts the cam:

Figure 2: Roller, Camshaft, and Tappet

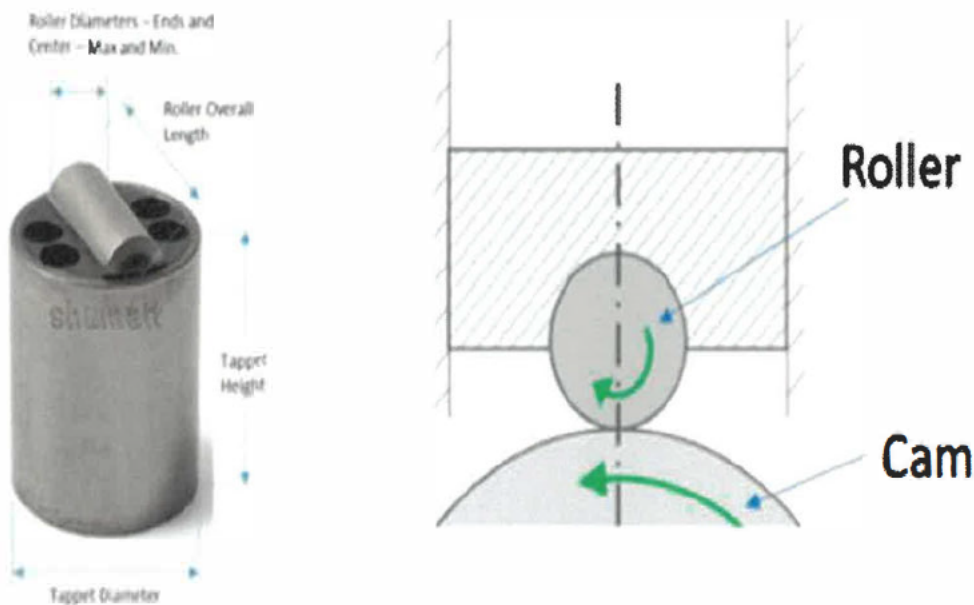

57.63. Below is a photograph showing a side-by-side comparison of the CP3 and CP4 fuel pumps, which illustrates how the contact area between the CP4 fuel pump's cam and roller is much smaller than the area between the CP3 fuel pump's ring and plunger foot:

Figure 3: Comparison of CP3 and CP4 fuel pumps

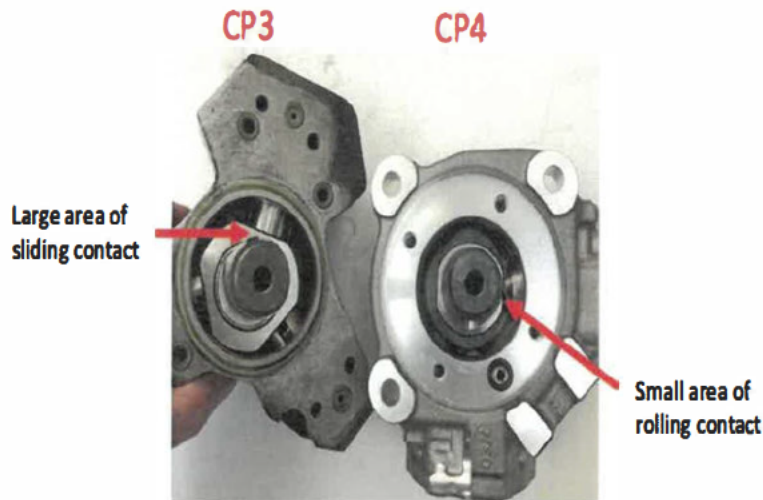

58.64. The design differences are further illustrated in the graphic below, which again shows the large surface contact area between the polygon and the plunger of the CP3 fuel pump as compared to the small line contact between the cam and the roller of the CP4 fuel pump:

Figure 4: Schematic Comparison of CP3 and CP4 Fuel Pumps

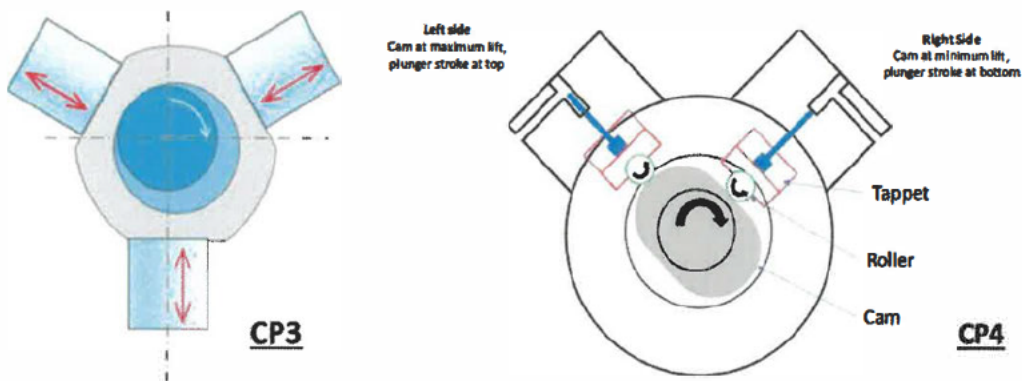

59:65. The CP3 fuel pump's sliding foot design distributes the load and reduces stresses on the polygon cam follower. It slides back and forth and does not need to roll to create a lubricating fluid film. Conversely, the CP4 fuel pump's cam-roller design results in very high forces along a single line of contact. The friction of the roller in the tappet must be less than the friction on the roller cam interface or else the roller will not rotate (or spin); instead it will slide. The roller also creates a hydrodynamic lubrication film of fuel between the roller and cam. This film is very thin, on the order of 1 micron or less (1 micron = 40 millionths of an inch). If the roller stops rotating and sticks or slips on the cam, it loses this lubrication film and starts to wear. In real world operating conditions, the result of all these factors is a lack of robustness because of the susceptibility to contamination through metal shavings or other debris, caused in part by metal-on-metal rubbing between the roller pin and the cam.

60:66. The critical roller pin design of the CP4 fuel pump creates very high stress (called Hertz stresses) as diagramed below:

Figure 5: Hertz Stresses on CP4 Fuel Pump Roller and Cam

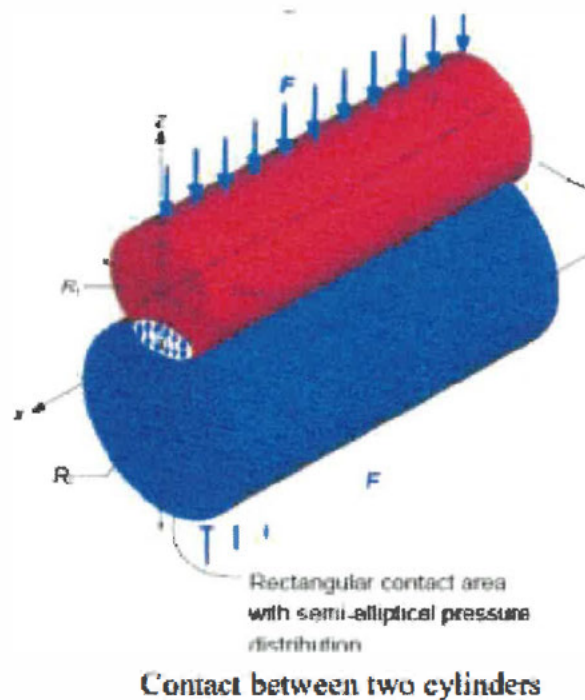

- 61:67. Comparing relative Hertz stresses of the CP3 fuel pump and CP4 fuel pump, the CP4 fuel pump roller-to cam contact Hertz stresses are about two times higher than the CP3 fuel pump. These higher stresses will increase contact fatigue and wear of the metal parts that come in contact with each other. In the case of the CP4 fuel pump, these parts are the roller and camshaft. Accordingly, use of the CP4 fuel pump for the same amount of force would be more likely to wear and fail than the CP3 fuel pump for same lubrication conditions of lubricity, viscosity, and fuel quality. This would be aggravated and increase wear dramatically if the roller pin stops rotating and starts sliding. Aggressive roller and cam wear changes the roller diameter to more of a slider and generates wear debris.
- 62:68. Unlike the CP3 fuel pump, which uses a sliding elephant's foot design to spread stresses and shortened distance of metal on metal travel, the CP4 fuel pump's cam-roller design results in very high forces along a single line of contact. The friction of the roller in the tappet must be less than the friction on the roller cam interface. The result of all these factors is fragility, and susceptibility to contamination through metal shavings or other debris, caused in part by metal-on-metal rubbing between the roller pin and the cam.
- 63:69. In addition to the design limitations referenced above, the tappet which houses the roller pin is not prevented from rotating around in its own axis inside the cylindrical pump housing. If the tappet does rotate out of position, the roller pin rotates from parallel to the camshaft, to perpendicular to the camshaft. Once rotated the roller will no longer rotate, and instead the cam slides across the roller, leading to wear and erosion, as a trough is being carved into the cam. The wear and erosion will generate metal shavings that are carried by the fuel throughout the fuel system, including downstream to the sensitive high-pressure fuel injectors. The photograph below at Figure 6 shows the severe wear and gouging caused by rotation of the tappet:

Figure 6: Wear on the Cam and Roller



- 64-70. The second issue is additional wear due to the metal-to-metal surface contact between the cam and roller, and metal-to-metal contact between the roller and roller shoe. This wear results in the creation of metal filings which can contaminate the fuel system and damage the injectors. The metal-to-metal wear can occur any time the roller stops rotating inside the tappet shoe. Metal particles that lodge inside the roller shoe can effectively jam the rolling pin in a stuck position. In addition, low viscosity caused by water in the fuel can reduce the film layer thickness the roller depends on to ride above the shoe.
- 65-71. If particles enter the roller shoe, and if the film of fluid is not thick enough, the hard diamond-like coating of the tappet roller shoe can wear off. As the coating wears, damage becomes progressively worse, even as the wearing generates more hard and fine particles that can make their way through the fuel system to the injectors. Below at Figure 7 is a close-up of a CP4 tappet roller shoe, showing abrasive wear of the coating:

Figure 7: Wear on the Diamond Coating

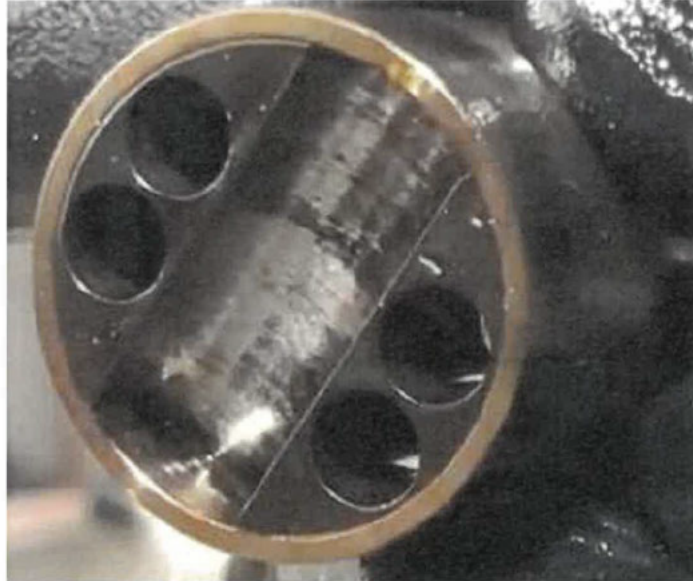

- 66-72. Finally, the CP4 fuel pump depends upon the fuel to lubricate the roller pin and the cam shaft and prevent wear. North American diesel fuel (as explained further below) is refined to a less lubricious specification limit as compared to European diesel fuel. North American fuel lubricity specifications are borderline for the CP4 fuel pump. Any fuel that is less than the minimum specified lubricity can lead to premature wear and/or failure.
- 67-73. Small wear particles (small enough to pass through the engine's filters, or created downstream of the filters through corrosion or wear) are problematic—and potentially catastrophic—for the CP4 fuel pump for two reasons. First, if the wear particles come in between the cam and the roller, they can create increased point-contact stresses which can damage the ultra-smooth faces of the components, eventually leading to spalling, cracking or loss of material. Second, if the wear particles lodge between the roller and the roller shoe they can cause the roller to stick. If the roller sticks or stops rolling it can cause the tappet to slide between the cam and the roller or to rotate out of alignment with the cam. Any of these conditions causes stress, metal fatigue, wear, and ultimately catastrophic failure.

- ~~68~~:74. Catastrophic failure can occur through accumulation of wear when the roller skids on the camshaft and aggressively wears to the point of complete roller and tappet breakdown. Large fragments of the worn parts can crack the fuel pump housing and cause fuel leakage to the engine compartment. Migration of wear particles into the common rail, injectors, and engine can cause progressive or sudden damage to the pump, injectors, engine, turbocharger, and after-treatment systems. Engine stall or failure to start can also occur which leads to a “mission disabling” failure, which leads to the vehicle either limping to a repair shop or becoming completely stranded on the side of the road.
- 69:75. Catastrophic failure occurs when the level of wear is so severe the pump plunger is not able to complete the full pressurizing stroke and the fuel pressure target is not achieved. If the pump is completely unable to pressurize the fuel, the engine will not start or if it is running, the engine will stop. As a result, the vehicle must be towed as it is no longer operable.
- ~~70~~:76. When a catastrophic CP4 fuel pump failure is confirmed, not only must the fuel pump itself be replaced, the entire high-pressure sub-system consisting of fuel lines, fuel rails, sensors, and injectors must be replaced as well. On the low-pressure side, the fuel tank must be drained and thoroughly cleaned, the fuel lines must be flushed, and the both fuel filters replaced. However, replacement of the fuel system and pump does not fix the problem. After a CP4 fuel pump failure occurs it is simply replaced by the Defendants, FCA, under its recalls by another defective CP4 fuel pump with the same basic fragile and unstable design with the same propensity for failure in the future. Owners and/or lessees of the Affected Class Vehicles who obtain new replacement fuel pumps and fuel systems under the Defendant, FCA’s, recalls are in the same position as they were before - operating an Affected Class Vehicle that has a fuel pump susceptible to the same conditions that could, once again, cause a catastrophic pump failure with its downstream failures and safety risks.
- ~~71~~:77. Even if the CP4 fuel pump does not catastrophically fail, small, micron-sized metal filings from the wearing process may enter into the high-pressure fuel system. This can lead to fuel injector damage, which impacts the precise control of fuel flow. Additional and unwanted excess fuel can lead to a number of issues including damaging or prematurely

ageing the pistons, cylinders, turbo charger, or the downstream after-treatment components.

72-78. Criticism of the CP4 fuel pump's fragile design and sensitivity to fuel quality began almost immediately after it was introduced in Europe in approximately 2007 describing how the pump can catastrophically fail, as well as how wear in the fuel pump can generate metal shavings which can cause injector problems and engine over-fueling. Below at Figure 8 shows damage that occurs, when the roller rotates on its axis, causing the cam to slide across the roller, rather than rolling together with it:

Figure 8: Effects of the Rotation of the Roller

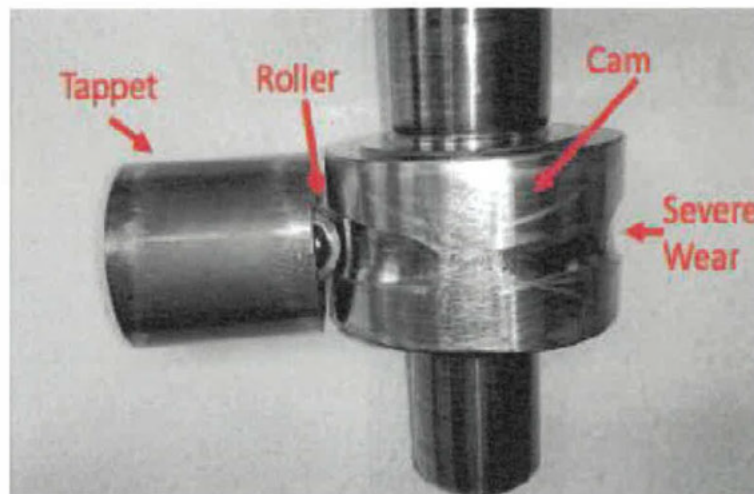

v. Characteristics of North American diesel fuel

73-79. As the foregoing suggests, for the CP4 fuel pump design to work, the properties and quality of diesel fuel are vitally important. Key fuel properties such as minimum levels of lubricity and viscosity must be met at all times throughout the life of the engine. If either property is compromised, then wear can occur, leading to shorter life and failure. As detailed below, the overall quality of diesel fuel in North America is inadequate for this design.

- 74:80. The CP4 fuel pump relies on diesel fuel itself to maintain lubrication. The lubricity of diesel in Europe is more standardized than North American diesel, but European diesel is also dirtier. Because the sulfur in diesel exhaust is a major cause of smog and acid rain, in 2007 the United States Environmental Protection Agency (“EPA”) required diesel fuel sold in the United States to have less than 15 ppm of sulfur. This is known as Ultra Low Sulfur Diesel (“ULSD”). It is produced through a refinery process known as hydrodesulfurization (“HDS”). Sulfur provides some of the lubricity needed for the fuel pump to operate. But the refinery process required to produce low sulfur diesel destroys a variety of important nitrogen and oxygen-based polar and organic compounds that give diesel fuel its lubricity. Indeed, ULSD fuel is considered to be very “dry” and incapable of lubricating vital diesel fuel delivery components, specifically high-pressure fuel pumps and injectors; as a result, North American diesel does not contain the lubrication necessary for the Bosch CP4 Pump to operate durably, and these fuel injection system components are at risk of premature and/or catastrophic failure when ULSD fuel is introduced to the system.
- 75:81. Low sulfur diesel fuel first appeared in the North American market in the 1990s, with fewer than 500 ppm of sulfur. It is estimated that 65 million fuel injection pumps failed as a result. It was thought that the fuel pumps failed at the equivalent of 100–200 hours of operation. Thus, the critical importance of lubricity for diesel injection pumps was well known to all vehicle manufacturers for a decade or more before the Affected Class Vehicles were designed or introduced into the market.
- 76:82. The main body that sets standards for diesel fuel is the American Society for Testing and Materials (“ASTM”): the specific standard for diesel fuel is known as the ASTM-D975, which has been adopted by the EPA and Environment Canada as a binding regulation. Lubricity in diesel fuel is quantified as measurement of wear. A test method called a high frequency reciprocating rig (HFRR) involves oscillating a weighted ball across a flat plate and measuring the scratches or “wear scar” pattern on the surface. The diameter of the wear scar (measured in micrometers) is thus an indicator of lubricity, with larger diameters indicating low (poor) lubricity fuel and smaller diameters indicating high (better) lubricity fuels.

77-83. In North America the minimum HFRR wear scar diameter is 520, compared to the European standard of 460 wear scar. Since the CP4 fuel pump is self lubricating with the diesel fuel it is pumping, the lubricity of North American diesel is crucial to the fuel pump's durability and longevity. And since the lubricity of the diesel fuel is a critical factor in the durability of the fuel pump, careful attention should have been paid to the difference in North American and European fuels.

78-84. Since as early as 2002, automotive engine manufacturers have been well aware of the mismatch between engine part specifications that require a maximum of 460 wear scar, and the lower lubricity specifications of ULSD.

79-85. Most diesel fuel in North America is produced by distillation of petroleum oil in a refinery. The fuel is refined and processed to meet certain specifications outlined in regulations and guidelines adopted by the EPA and/or Environment Canada. The refinery also blends additives into the fuel to meet the applicable specifications. Once North American diesel fuel is produced in the refinery it enters a distribution system where it travels to terminals and then ultimately to a fuel pumping station. In North America, fuel may be transported in a variety of ways included pipelines, trucks, and rail. Figure 9 below is a schematic showing the flow of fuel from its source (crude oil) through refining and distribution:

Figure 9: Transport of Fuel from Source to Gas Station

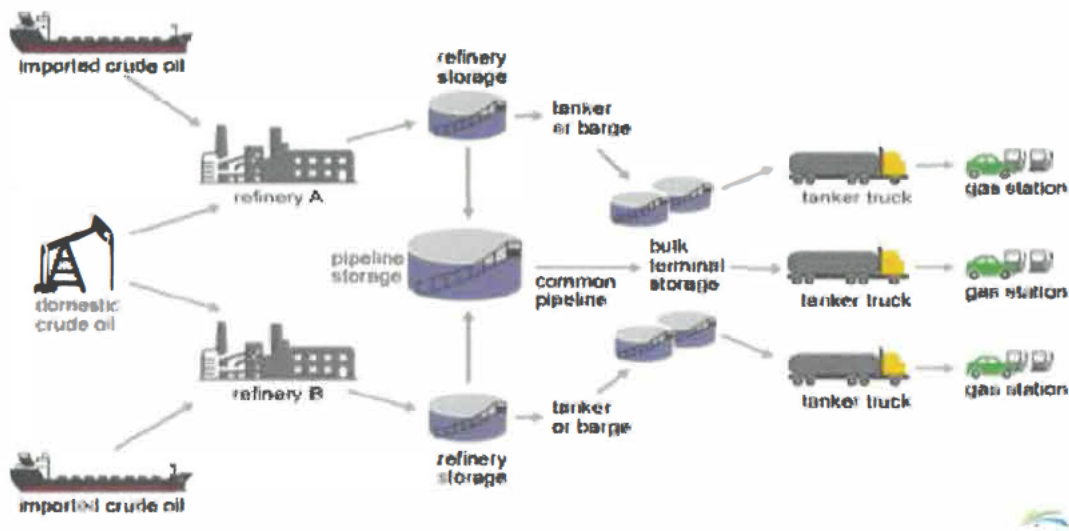

~~80:~~86. Fuel is tested to ensure it meets ASTM specification once it leaves the refinery and again when it leaves the bulk terminal. Fuel may be blended (with biodiesel for example), or enhanced with various additives at either the refinery or the terminal. Although there is a system in place to try to achieve uniformity of fuel quality, as described below, in practice there are a number of factors that lead to the frequent production of substandard quality fuel.

vi. The unreliability of North American diesel fuel

~~81:~~87. Despite EPA and Environment Canada requirements, in reality, North American diesel frequently contains even less than 15 ppm of sulfur, which is widely known in the automobile industry.

~~82:~~88. According to Infineum's 2014 Worldwide Winter Diesel Fuel Quality Survey testing 341 diesel fuel samples from around the world, all diesel fuel samples the organization collected and tested from the United States and Canada contained sulfur levels of 10 ppm or less.

~~83:~~89. Other fuel surveys indicate that North American diesel wear scar differs drastically across the continent and thus does not uniformly offer sufficient lubrication for the fuel pump. For example, in 2018 Infineum conducted a survey of the lubricity of North American diesel fuel from various regions of the continental United States and found that there are certain locations where the fuel is not lubricious enough, and the CP4 fuel pump's design leaves little margin for error. Over the course of a vehicle's lifetime, a driver will likely use diesel fuel that is "dry," which will lead to the damage to the engine outlined herein.

90. However, with the advent of ULSD fuel, high-lubricity fuels are hard to obtain and the consumer has no way of knowing the lubricity of the fuel at a standard retail filling station. To that extent, about three in ten diesel fuel stations violate European lubricity standards (460 wear scar), which is the minimum standard for the CP4 fuel pump to operate effectively. As such, it seems all but inevitable that vehicle owners will eventually fill up their vehicles with diesel fuel that is "dry" and harmful to the vehicles' engines.

vii. Water in North American diesel fuel

84:91. North American diesel fuel can also easily degrade and move off specification during transportation and storage, including from the entry of water into the fuel. Water can seep into the fuel supply, which decreases the fuel's viscosity. During transfer of fuel—either from refinery to storage tanker, or from tanker to the pump—air can get into the fuel. When the air cools, water condenses and drops into the tank. If this occurs, the fuel loses viscosity, which has a directly negative effect on its lubricity, resulting in an insufficient layer of protection between the roller pin and the tappet shoe.

85:92. The potential for water to get into the fuel supply is a well-known and easily anticipatable problem for vehicle manufacturers, such as the Defendant, FCA. Diesel fuel tanks “breathe” through filler caps and vents, and as fuel is withdrawn by the fuel pump, humid air can enter the fuel tank and water can condense when the fuel tank cools. Yet the Defendant, FCA, continues to blame customers for water in the fuel, based on the unconvincing assumption that the consumers are at fault for what is a foreseeable condition to the vehicle manufacturer.

viii. Dirt or corrosion particles and gasoline contamination in North American diesel fuel

86:93. Diesel fuel can become contaminated by dirt or corrosion particles. Fuel tanks can become rusty through exposure to air. The net result of contamination is the particles clog up the two filters in the fuel injection system.

87:94. Diesel fuel can also become contaminated with gasoline or other liquids, partly when diesel is held in storage tanks or transported in tanker trucks that previously contained gasoline, kerosene, or other liquid fuels or petroleum products. Since gasoline is less viscous, it makes the diesel less viscous as well, which decreases its lubricity.

88:95. Given that the CP4 fuel pump is a critical part of the engine system, it must be designed for very long life and, most importantly, must be capable of operating with commercially available fuel. A reasonable, prudent vehicle manufacturer has a duty to design or select

a fuel injection pump designed for the fuel of the country in which the vehicle is to be sold. Yet, the Defendant, FCA, had Bosch supply its inherently incompatible CP4 fuel pump for use in the Affected Class Vehicles, beginning in the 2014 model year. It was certainly no secret to the Defendant, FCA, that the Bosch CP4 fuel pump is inappropriate for North American diesel vehicles. As such, the Defendant, FCA, failed to provide a safer alternative design for a high-pressure fuel injection system in the Affected Class Vehicles that could withstand North American diesel fuel specifications in terms of lubrication and water content. A safer alternative design for the CP4 fuel pump was to incorporate a sliding foot design similar to the CP3 fuel pump rather than a cam-roller design.

ix. Pre-class period CP4 fuel pump failures and industry knowledge

89.96 The Bosch CP4 fuel pump was defective and incompatible with North American diesel fuel from the get-go, even prior to its usage in the Affected Class Vehicles. For example, on February 7, 2011 the Office of Defect Investigations (“ODI”) at NHTSA opened safety investigation No. EA11-003 based on 160 complaints “alleging incidents of engine stall and/or loss of power that appear to be related to high pressure fuel pump failures in certain model year 2009 through 2010 Volkswagen Jetta and 2010 Volkswagen Gold and Audi A3 vehicles equipped with [turbo diesel engine] clean diesel engines. Approximately half of the reports indicate that the failure resulted in an engine stall incident, with many of these alleging stall incidents at highway speeds in traffic with no restart.” During this investigation, ODI requested documents not only from Volkswagen and Bosch, but also from Ford, General Motors and the Defendant, FCA. Documents that the vehicle manufacturers produced were subsequently published on NHTSA’s website. These documents demonstrate widespread—and early—knowledge of the fuel pump defect and its potentially catastrophic effects. By the end of 2011, it was well known that Bosch CP4 fuel pump failures in North American Audi and Volkswagen vehicles were widespread and catastrophic.

90.97. Although the NHTSA ODI investigation involved Bosch and Audi or Volkswagen, the Defendant, FCA, engineers almost certainly would have heard about these problems early on. Vehicle manufacturers such as the Defendant, FCA, and component manufacturers such as Bosch, have significant and dedicated departments which continuously monitor

regulatory compliance with safety, emissions, customs, and tax laws. Their marketing departments monitor their competitors and public domain information to track emerging trends which may impact their business, such as the release of new competitive products or problems with commonly used components on other manufacturer's products. These departments maintain extensive databases of competitive information including design details, teardown analyses and reverse engineering to maintain their competitive edge or comparative advantage. These databases are searchable by employees and information is pushed to new product development teams.

- 91.98. Specific departments in original equipment manufacturers ("OEMs") (including Product Compliance, Liability, and Environmental Management) will monitor many public (and subscription) sites such as truckandenginemanufacturers.org, NHTSA.gov, EPA.gov, the California Air Resources Board (ww2.arb.ca.gov), Transport Canada (<https://tc.canada.ca/en>), Environment Canada (<https://www.ec.gc.ca/>) and international agencies (e.g., www.cen.eu, ASTM.org) to ensure compliance with all standards, regulations and awareness of changing regulations, recalls, and safety-related issues, among others. They will also subscribe or fund firms to do this analysis and information gathering for them. They also employ lobbyists in government agencies to keep abreast of new situations. These firms are all well informed about market conditions and product liability potential issues.
- 92.99. In addition, motor vehicle safety acts in the United States (49 U.S. Code 301 - Motor Vehicle Safety Act) and Canada (*Motor Vehicle Safety Act*, R.S.C.1993, c.16) and related regulations, require the quarterly submission to NHTSA and Transport Canada of "early warning reporting" data, including claims relating to property damage received by the automotive manufacturer, warranty claims paid by the automotive manufacturer, consumer complaints, incidents involving injury or death, and field reports prepared by the automotive manufacturer's employees or representatives concerning failure, malfunction, lack of durability, or other performance issues.
- 93.100. Emerging problems (such as the NHTSA investigation of Volkswagen/Audi CP4 fuel pump failures) would certainly be tracked by the Defendant, FCA, and other OEMs. There are government regulatory requirements mandating such tracking. Relevant information

would be condensed and pushed to design, development, testing, service and quality departments to ensure that they were aware of these emerging problems. These global firms maintain extensive bodies of knowledge such as “lessons learned” or “engineering standard work” databases to ensure that problems encountered internally or externally are codified into their own standards and disseminated to working levels of engineering, design, quality and service. “Lessons learned” from competitors are invaluable since they avoid similar problems during development and production. These “lessons learned” databases are particularly important when OEMs develop global products at multiple engineering centers around the world. “Lessons learned” and competitive bench marking are key steps in the Design Validation Planning of all major OEMs and part of their “Value Analysis” studies for New Product Introduction.

94.101. In addition, working level engineers and designers also are encouraged to join trade organizations such as the Society of Automotive Engineers, American Society of Mechanical Engineers, and ASTM, and to subscribe to many trade publications and trade shows to stay current with changing requirements and competitive information. When a new product, regulation, standard, or issue is being announced or rumored, all major automotive news organizations will investigate and report on these developments since they are crucial for the OEMs’ business. Product problems are also tracked closely since they affect stock market valuations and warranty accruals in United States Security Exchange Commission filings.

95.102. Government organizations such as NHTSA, EPA, Transport Canada, Environment Canada and CARB routinely push information to OEMs and require responses to ensure that they are on notice of emerging safety issues, recalls, emissions and safety compliance changes. This information is required to be published broadly by OEMs within their internal websites to employees to put them on notice, and there are compliance audits to ensure that employees are trained and certified where necessary.

96.103. The NHTSA and/or Transport Canada recalls and investigations would certainly be communicated to the product development, quality, purchasing, and service teams of the Defendant, FCA.

97.104. As such, information about the CP4 fuel pump's problems would have been widely known throughout the automobile industry, and certainly known to the Defendant, FCA.

x. The Fuel Pump Defect poses a real, imminent and substantial danger to vehicle occupant safety and renders the Affected Class Vehicles *per se* defective

98.105. As stated above, government regulations in both the United States and Canada (49 U.S. Code 301- Motor Vehicle Safety Act and *Motor Vehicle Safety Act*, R.S.C. 1993, c.16) require that vehicle manufacturers to disclose to NHTSA and Transport Canada respectively of "early warning reporting" data, including claims relating to property damage received by the automotive manufacturer, warranty claims paid by the automotive manufacturer, consumer complaints, incidents involving injury or death, and field reports prepared by the automotive manufacturer's employees or representatives concerning failure, malfunction, lack of durability, or other performance issues.

99.106. Further, these government regulations require immediate action when a vehicle manufacturer determines or should determine that a safety defect exists. A safety defect is defined by regulation to include any defect that creates an "unreasonable risk of accidents occurring because of the design, construction, or performance of a motor vehicle" or "unreasonable risk of death or injury in an accident." Within a period of time of learning about a safety defect, a manufacturer must notify NHTSA and Transport Canada and provide a description of the vehicles potentially containing the defect, including "make, line, model year, [and] the inclusive dates (month and year) of manufacture," a description of how these vehicles differ from similar vehicles not included in the recall, and "a summary of all warranty claims, field or service reports, and other information" that formed the basis of the determination that the defect was safety related. Then, "within a reasonable time" after deciding that a safety issue exists, the manufacturer must notify the owners of the defective vehicles. Violating these notification requirements can result in a substantial civil penalty.

100.107. The Defendant, FCA, knew or ought to have known about the Fuel Pump Defect as evidenced by: (1) consumer complaints lodged with NHTSA, Transport Canada and elsewhere online; (2) warranty claims, part sales, and consumer complaints lodged with

the Defendant directly; (3) technical service bulletins and/or safety recalls issued by the Defendant, FCA, in an attempt to address the Fuel Pump Defect; (4) the Defendant's, FCA's, own pre-sale durability testing of the Affected Class Vehicles; and (5) communications with the fuel pump supplier, Bosch.

~~101.~~108.The internet is replete with consumer complaints about the Fuel Pump Defect in the Affected Class Vehicles alleging incidents of stall/loss of motive power as a result of high pressure fuel pump failures and the danger it poses to drivers and occupants. The Defendant's, FCA's, customer relations departments routinely monitor the internet for customer complaints and retain the services of third parties to do the same. The Defendant's, FCA's, customer relations divisions regularly receive and respond to customer calls concerning, *inter alia*, product defects. Through these sources, the Defendant, FCA, was made aware of the Fuel Pump Defect. Based on its commercial interests and its duty to monitor safety-related complaints or concerns, the Defendant, FCA, assuredly saw scores of consumer complaints regarding the CP4 fuel pump failure, including the Defendant, FCA, manufactured vehicles at issue in earlier litigation in the United States. The complaints indicate the Defendant, FCA's, knowledge of the Fuel Pump Defect and its real and substantial danger to drivers and occupants of the Affected Class Vehicles.

xi. Progressive CP4 fuel pump failures

~~102.~~109.In addition to catastrophic CP4 fuel pump failure, there are harmful consequences from the progressive failure that the fuel pump exhibits. Early symptoms of progressive failure of the CP4 fuel pump include malfunction and failure of the precision common rail fuel injectors. Microscopic metal debris from the CP4 fuel pump may slip past the filter in the metering valve and into the pumping chambers of the CP4 fuel pump, and then flow out to the downstream fuel pipes, fuel rails, and to the injectors, thereby contaminating the whole fuel system with microscopic debris. The openings in the injectors are very small (a few microns), and microscopic pump wear debris can either hold the injector nozzle needle open, or closed, or slow its opening and closing rate.

103.110. If the injector nozzle needle is left open too long or stuck open, this will result in gross over-fueling of the combustion chamber, which can lead to progressive damage of the power cylinder (including the piston, rings, block, connecting rod, and crankshaft). Over-fueling can overheat the piston and result in a twisted or melted piston, or burn a hole in the piston. Over-spray penetration can also result in dilution of the lube oil on the power cylinder walls and lead to scuffing and eventual failure of the piston, connecting rod, and the engine block. Severe dilution of the lube oil can also damage engine and rod main bearings and other oil-lubed running surfaces.

~~104.~~ 111. A stuck or sticking injector which causes over-fueling can also increase fuel consumption and thereby reduce fuel economy. The air-fuel ratio of modern diesels is 18 parts air to one part fuel or higher (18:1–70:1, or what is called “lean burn”) for optimal combustion. But when the injectors are sticking open or blocked open, the fueling becomes uncontrolled (by the electronic control unit) and air/fuel ratios can become much richer than design calibration. This increases the potential for white smoke (unburned fuel), black smoke (burned but wasted fuel), combustion pressures, and temperatures and emissions (NO_x, particulate matter, CO, CO₂, and unburned hydrocarbons) beyond capabilities of exhaust after treatment systems to control. Fuel economy will also likely decline since the wasted fuel to produce the smoke is not doing work to produce power, and so kilometers per gallon should be reduced.

~~105.~~ 112. In addition, a blocked closed injector (due to wear debris) forces the engine control system to demand more fueling from the remaining functional injectors to compensate for the loss of a power cylinder, and this can also cause reduced performance and increased fuel consumption/reduced fuel economy.

~~106.~~ 113. In some cases, injector nozzle tips can be broken by wear debris trapped in spray holes or under the nozzle needle seat, essentially turning the injector into an open fuel hose. A broken nozzle tip can result in gross over-fueling which may cause hydraulic lock and bending of the connecting rods. Over-fueling also causes over-temperature conditions which can damage exhaust valves, cylinder heads, exhaust manifolds, turbochargers and after treatment systems. These progressive damages can occur before the CP4 fuel pump catastrophically fails, and causes noticeable loss of fuel pressure warnings, engine stall,

or no start conditions which forces the consumer to seek a repair and pump replacement. Fuel systems contaminated with microscopic wear debris must be completely replaced including fuel pressure pipes, rails, pressure sensors and injectors.

~~407.114.~~ In short, the Affected Class Vehicles are inherently less durable than previous models because of the CP4 fuel pump defect. Less durability means that Affected Class Vehicle owners will experience more repair costs.

xii. Timeliness and adequacy of the Defendant's FCA's, recalls

115. The *Motor Vehicle Safety Act*, R.S.C. 1993, c.16 requires giving a notice of defect when a vehicle manufacturer determines, or should determine, that a safety defect exists. A safety defect includes, *inter alia*, any defect in the design, manufacture or functioning of the vehicle or equipment that affects or is likely to affect the safety of any person.

116. Upon becoming aware of a safety defect, a vehicle manufacturer must notify the Minister of Transport and provide:

- (a) a description of the vehicles potentially containing the defect including, *inter alia*, the prescribed class, make, model, and model year for each vehicle that may contain the defect;
- (b) the period during which the vehicles were manufactured;
- (c) the estimated number of vehicles that could potentially contain the defect;
- (d) a description of the nature of the defect;
- (e) a description of how these vehicles differ from similar vehicles not included in a recall;
- (f) a summary of all warranty claims;

- (g) field or service reports;
- (h) other information that formed the basis of the determination that the defect exists;
- (i) a description of the safety risk to persons arising from the defect;
- (j) a description of the corrective measures to be taken; and
- (k) any precautions that may be taken to minimize the safety risk until the corrective measures are implemented.

Then, within a reasonable time after deciding that a safety issue exists, the vehicle manufacturer must notify the owners and/or lessees of the defective vehicles. Violating these notification requirements can result in civil penalties.

117. While the Defendant, FCA, did issue manufacturer recalls in or around June 2022 and April 2023, which led to Transport Canada recalls issued on or about June 9, 2022 for 2014-2020 Jeep Grand Cherokees and Dodge Ram 1500 vehicles and on or about April 13, 2023 for 2021-2023 Jeep Wranglers and Gladiators and 2022-2023 Dodge Ram 1500 vehicles, these recalls were issued much later than when the Defendant, FCA, knew or should have known of the Fuel Pump Defect and its safety risks, as set out in paragraphs 96-104 above, including that the Defendant, FCA, had notice of the Fuel Pump Defect via replacement part sales, warranty repair requests, indirect complaints from customers through online forms, NHTSA complaints, NHTSA ODI investigation of Audi and Volkswagen CP4 fuel pump failures, other vehicle manufacturers, industry sources, including articles, white papers, testing, and investigations.

118. Even in Affected Class Vehicles where a recall remedy was completed, the recall remedy itself remains insufficient and does not mitigate the safety risks to Class Members, as the replacement CP4 fuel pump remains susceptible to catastrophic failure and damage to downstream fuel and engine component parts given that the replacement CP4 fuel pump suffers from the same basic fragile and unstable design as the original equipped CP4 fuel pump in the Affected Class Vehicles.

119. The recalls initiated by the Defendant, FCA, as described herein, were insufficient to mitigate, let alone eliminate, the imminent threat of harm to the Plaintiff and Class Members, nor the substantial out-of-pocket repair costs associated with the Fuel Pump Defect. Pursuant to the *Motor Vehicle Safety Act*, R.S.C. 1993, c.16, the Plaintiff and Class Members are entitled to pursue their claims for damages with respect to the Fuel Pump Defect via litigation.

xii-xiii. In falsely trumpeting the quality, performance, and dependability of its EcoDiesel engine vehicles to consumers, the Defendant, FCA, concealed, affirmatively and by omission, the defective nature of the CP4 fuel pump

~~108.~~ 120. At least from 2013 through 2018, the Defendant, FCA, has extensively advertised the performance benefits of the EcoDiesel engine located within all of the subject Affected Class Vehicles. At all material times relevant to this proposed class proceeding, the Defendant, FCA, omitted and/or concealed the CP4 Fuel Pump Defect. Indeed, at no point during the period relevant to this action did the Defendant, FCA, inform purchasers and/or lessees of the Affected Class Vehicles that the Bosch-supplied CP4 fuel pump and accompanying fuel system components within the EcoDiesel engine were incompatible with the ordinary use of North American diesel fuel, or that the defective CP4 fuel pump starts damaging the vehicle's fuel injection system and engine immediately upon the vehicle's first use. In fact, the Defendant's, FCA's, advertisements represent that the Affected Class Vehicles are fit for driving on North American roadways, which implies that North American diesel fuel is being used in, and compatible with, the Affected Class Vehicles; this is simply not true from day one.

~~109.~~ 121. Likewise, the Defendant, FCA, repeatedly told consumers that the Affected Class Vehicles were dependable, long-lasting, and of the highest quality. In so doing, the Defendant, FCA, led consumers, including the Plaintiff and putative Class Members, to believe that the Affected Class Vehicles would be free from defects that result in fuel injection system failure and consequential engine shutdown which results in outrageously expensive repair costs.

~~110.~~ 122. In its brochures and advertisements for the Affected Class Vehicles, the Defendant, FCA,

consistently touted the performance benefits of the EcoDiesel engine. For example, the Defendant's, FCA's, advertisement brochure for the 2014 Grand Jeep Cherokee touts the new 3.0L EcoDiesel engine, claiming it "treat[s] your fuel budget with respect," with "EFFICIENCY—30 MPG." The efficiency of FCA's EcoDiesel-equipped Ram trucks was promoted with the phrase, "SAY HELLO TO LOWER COST OF OWNERSHIP," touting the vehicles' 28 MPG fuel efficiency.

~~441~~.123. The Defendant, FCA, further claimed that its 2014 Dodge RAM EcoDiesel vehicles were durable in spite of varying fuel quality, touting that "the available 3.0L EcoDiesel V6 utilizes dual-filtration technology for greater . . . durability."

~~442~~.124. The 2015–16 brochures for the Jeep Grand Cherokee also features the EcoDiesel badge, which touts best-in-class fuel economy, range, horsepower, and torque.

~~443~~.125. In its EcoDiesel advertising, the Defendant, FCA, specifically targets consumers "who want to drive an efficient, environmentally friendly truck without sacrificing capability or performance." Indeed, it claims that the RAM 1500 EcoDiesel was "the NAFTA market's first and only light-duty pickup powered by clean diesel technology."

~~444~~.126. The Defendant, FCA, also claims that the EcoDiesel engines equip the RAM 1500 with the "best fuel economy of any full-size pick-up" and the Jeep Grand Cherokee "with an incredible 730- mile highway driving range, you can find hundreds of miles of discovered roads and be confident you'll find your way back."

~~445~~.127. Another theme of the Defendant's, FCA's, misleading advertising campaign is the Affected Class Vehicles' power, including torque and towing capacity. The Defendant, FCA, claims that the 2015 Jeep Grand Cherokee equipped with a 3.0-liter EcoDiesel V6 engine has best-in-class towing capability of up to 7,400 pounds. Similarly, the Defendant, FCA, claims that the EcoDiesel engine has best-in-class torque: "The EcoDiesel engine delivers best-in-class 420 lb-ft of torque. Paired with an impressive 240 horsepower, this engine has serious muscle."

~~446~~.128. The Defendant's, FCA's, promotional materials have claimed that the RAM 1500

EcoDiesel engine “delivers the highest fuel economy among all full-size truck competitors—12% higher than the next-closest competitor. On the Jeep Grand Cherokee, it offers fuel economy of 30 miles per gallon highway with a driving range of more than 730 miles.”

~~117.~~129. The Defendant, FCA, also promotes the power and performance of the EcoDiesel engine on its website, noting that “[t]he EcoDiesel engine delivers best-in-class 420 lb-ft of torque. Paired with an impressive 240 horsepower, this engine has serious muscle.”

~~118.~~130. Other online advertisements proclaim that the Dodge RAM 1500 EcoDiesel is “expected to deliver an outstanding combination of best-in-class fuel efficiency, best-in-class torque and impressive capability. This new EcoDiesel is among today’s most advanced diesel engines. Has emissions that are 60% lower than those produced by diesel powertrains 25 years ago. The impressive combination of torque and fuel economy marks a new level of performance.”

~~119.~~131. The Defendant, FCA, has touted the Dodge RAM Truck brand as “the most innovative lineup of full-size trucks on the market” and boasts of the vehicles’ “durable engines and features that further enhance their capabilities.” Ironically, the Defendant, FCA, notes in this same advertisement that, “Truck customers, from half-ton to commercial, have a demanding range of needs and require their vehicles to provide high levels of capability. Ram trucks are designed to deliver the total package.”

~~120.~~132. The Defendant’s, FCA’s, advertising for the 2015 Dodge RAM 1500 EcoDiesel includes the representation that the vehicle has “the best fuel economy of ANY full-size pickup,” and that it “offer[s] advantages that separate you from the rest of the pack: exceptional torque and superior fuel-efficient performance, welcome biodiesel (B20) capability . . . and a zero-hassle DEF System.”

~~121.~~133. For the 2016 Dodge RAM 1500 EcoDiesel, the Defendant, FCA, similarly advertised that the “3.0L EcoDiesel V6 delivers biodiesel (B20) capability; a zero-hassle DEF System; clean dual-filtration technology; minimal CO₂ levels; and . . . [t]he crowning touch? Its best-in-class 29 mpg highway fuel economy.”

~~122.~~134.The Defendant, FCA, has represented in its television, internet, and printed advertisements that the Affected Class Vehicles are fit for driving on North American roadways, by featuring the Affected Class Vehicles driving on North American roadways. In these advertisements, numerous Affected Class Vehicles are seen traveling all sorts of North American terrain as if they are all adequately drivable and compatible with North American diesel fuel, but they are not.

~~123.~~135.The Affected Class Vehicle brochures and related marketing materials, seen and/or heard by putative Class Members prior to purchase, are tied together by common themes and sometimes identical language. The specific language outlined above in the Defendant's, FCA's, marketing and advertising are false, misleading, and deceptive, as are the demonstrations of the Affected Class Vehicles being driven on North American roadways which falsely represents that the vehicles are compatible with North American diesel fuel.

~~xiii.~~xiv.The Defendant, FCA, designed, manufactured, distributed, and sold vehicles it knew would experience catastrophic failures which the Defendant, FCA, would not honor under its warranties

~~124.~~136.In addition to the aforementioned representations, the Defendant, FCA, also provided an express 5-year/100,000-kilometer written warranty on the Affected Class Vehicles it manufactured. This Powertrain Limited Warranty specifically covers " Diesel Engine . . . fuel injection pump and injectors."

~~125.~~137.On many occasions, however, the Defendant, FCA, has refused to honor its warranties—even after its EcoDiesel customers presented the same fuel pump problem in the Affected Class Vehicles two (or more) times for repair under warranty. In return, the Defendant, FCA, has disingenuously claimed that the metal shavings and Affected Class Vehicle failures are not caused by the Defendant, FCA, and thus not covered under warranty.

~~126.~~138.Despite the clear mis-match between the CP4 fuel pump and North American diesel fuel, the Defendant, FCA, has not hesitated to pass the average \$8,000–\$10,000 cost of catastrophic failure along to the consumer. The Defendant's, FCA's, logic apparently is

that when the CP4 fuel pump self-destructs because of its innate incompatibility with North American diesel, and produces metal shavings in the fuel, which is then launched into the high-pressure fuel system and the engine, then the fuel supply is contaminated. Warranties do not cover the use of contaminated fuel. Because the fuel is now contaminated with metal from the pump, the repairs are for fuel contamination and are not covered by the warranties.

~~127.~~139. The Defendant, FCA, induced the Plaintiff and putative Class Members to pay a premium for increased durability, performance and fuel efficiency, with a design it has long known would cause fuel contamination—a condition the Defendant, FCA, now uses to absolve itself of the catastrophic and costly consequences to the Plaintiff and putative Class Members.

~~128.~~140. In sum, the Defendant's, FCA's, decision to use the Bosch CP4 fuel pump in the EcoDiesel engine was a grave error, particularly because of the varying and unpredictable levels of lubricity of North American diesel fuel. The CP4 fuel pump is the most important component on a modern diesel engine. If it fails, the engine is not operational, and when it generates metal debris, the fine material makes its way into the sensitive high-pressure components such as the fuel injectors.

~~129.~~141. All acquirers of the Affected Class Vehicles are harmed because progressive damage to the Affected Class Vehicles is inevitable. Even when the engines do not experience catastrophic failure, the fragile design causes damage to the engine and component parts, including broken injector tips, over-fueling, melted or damaged pistons, exhaust valves, turbochargers, cylinder heads, exhaust manifolds, and damage to the emission control system. Although no vehicle design is flawless, and some wearing of parts is inevitable and permissible, the use of the CP4 fuel pump in the Affected Class Vehicles posed an unacceptable and preventable risk of damage to the Affected Class Vehicles.

xiv.xv. Agency relationship between Defendant, FCA, and its authorized dealerships as to the Affected Class Vehicles

~~130.~~142. The Defendant, FCA, as the vehicle manufacturer, impliedly or expressly acknowledged

that FCA-authorized dealerships are its sales agents, the dealers have accepted that undertaking, it has the ability to control authorized FCA dealers, and it acts as the principal in that relationship, as is shown by the following:

- (a) The Defendant, FCA, can terminate the relationship with its dealers at will;
- (b) The relationships are indefinite;
- (c) The Defendant, FCA, is in the business of selling vehicles as are its dealers;
- (d) The Defendant, FCA, provides tools and resources for FCA dealers to sell vehicles;
- (e) The Defendant, FCA, supervises its dealers regularly;
- (f) Without the Defendant, FCA, the relevant FCA dealers would not exist;
- (g) The Defendant, FCA, as the principal, requires the following of its dealers:
 - (i) Reporting of sales;
 - (ii) Computer network connection with the Defendant, FCA;
 - (iii) Training of dealers' sales and technical personnel;
 - (iv) Use of the Defendant's, FCA's, supplied computer software;
 - (v) Participation in the Defendant's, FCA's, training programs;
 - (vi) Establishment and maintenance of service departments in FCA dealerships;
 - (vii) Certification of Defendant, FCA, pre-owned vehicles;

- (viii) Reporting to the Defendant, FCA, with respect to the car delivery, including reporting Plaintiffs' names, addresses, preferred titles, primary and business phone numbers, e-mail addresses, vehicle VIN numbers, delivery date, type of sale, lease/finance terms, factory incentive coding, if applicable, vehicles' odometer readings, extended service contract sale designations, if any, and names of delivering dealership employees; and
 - (ix) Displaying the Defendant's, FCA's, logos on signs, literature, products, and brochures within FCA dealerships.
- (h) Dealerships bind the Defendant, FCA, with respect to:
- (i) Warranty repairs on the vehicles the dealers sell; and
 - (ii) Issuing service contracts administered by the Defendant, FCA.
- (i) The Defendant, FCA, further exercises control over its dealers with respect to:
- (i) Financial incentives given to FCA dealer employees;
 - (ii) Locations of dealers;
 - (iii) Testing and certification of dealership personnel to ensure compliance with the Defendant's, FCA's, policies and procedures; and
 - (iv) Customer satisfaction surveys, pursuant to which the Defendant, FCA, allocates the number of Defendant, FCA, cars to each dealer, thereby directly controlling dealership profits.
- (j) FCA dealers sell Defendant, FCA. vehicles on the Defendant's, FCA's, behalf, pursuant to a "floor plan," and the Defendant, FCA, does not receive payment for its cars until the dealerships sell them.

- (k) Dealerships bear the Defendant's, FCA's, brand names, use its logos in advertising and on warranty repair orders, post FCA-brand signs for the public to see, and enjoy a franchise to sell the Defendant's, FCA's, products, including the Affected Class Vehicles.
- (l) The Defendant, FCA, requires FCA dealers to follow the rules and policies of the Defendant, FCA, in conducting all aspects of dealer business, including the delivery of the Defendant's, FCA's, warranties described above, and the servicing of defective vehicles such as the Affected Class Vehicles.
- (m) The Defendant, FCA, requires its dealers to post the Defendant's, FCA's, brand names, logos, and signs at dealer locations, including dealer service departments, and to identify themselves and to the public as authorized FCA dealers and servicing outlets for the Defendant's, FCA, vehicles.
- (n) The Defendant, FCA, requires its dealers to use service and repair forms containing its brand names and logos.
- (o) The Defendant, FCA, requires FCA dealers to perform the Defendant's, FCA's, warranty diagnoses and repairs, and to do the diagnoses and repairs according to the procedures and policies set forth in writing by the Defendant, FCA.
- (p) The Defendant, FCA, requires FCA dealers to use parts and tools either provided by the Defendant, FCA, or approved by Defendant, FCA, and to inform the Defendant, FCA, when dealers discover that unauthorized parts have been installed on one of the Defendant's, FCA's, vehicles.
- (q) The Defendant, FCA, requires dealers' service and repair employees to be trained by the Defendant, FCA, in the methods of repair of FCA-brand vehicles.
- (r) The Defendant, FCA, audits FCA dealerships' sales and service departments and directly contacts the customers of said dealers to determine their level of satisfaction with the sale and repair services provided by the dealers; dealers are then granted

financial incentives or reprimanded depending on the level of satisfaction.

- (s) The Defendant, FCA, requires its dealers to provide it with monthly statements and records pertaining, in part, to dealers' sales and servicing of the Defendant's, FCA's, vehicles.
- (t) The Defendant, FCA, provides technical service bulletins and messages to its dealers detailing chronic defects present in product lines, and repair procedures to be followed for chronic defects.
- (u) The Defendant, FCA, provides its dealers with specially trained service and repair consultants with whom dealers are required by the Defendant, FCA, to consult when dealers are unable to correct a vehicle defect on their own.
- (v) The Defendant, FCA, requires FCA-brand vehicle owners to go to authorized FCA dealers to obtain servicing under the Defendant's FCA's, warranties.
- (w) FCA dealers are required to notify the Defendant, FCA, whenever a car is sold or put into warranty service.

Part 2: RELIEF SOUGHT

1. The Plaintiff, on her own behalf and on behalf of putative Class Members, claims against the Defendants, FCA CANADA INC. and FCA US LLC, jointly and severally, as follows:
 - (a) an order certifying this action as a class proceeding and appointing the Plaintiff as the named representative;
 - (b) a declaration that the Affected Class Vehicles contain the Fuel Pump Defect;
 - (b)(c) a declaration that the Defendants, FCA CANADA INC. and/or FCA US LLC, were negligent in the design and/or manufacturing of the Affected Class Vehicles equipped with a 3.0L EcoDiesel engine with a defective high-pressure fuel

injection pump causing the Plaintiff and putative Class Members to suffer damages;

(d) a declaration that the Defendants, FCA CANADA INC. and/or FCA US LLC, owed the Plaintiff and putative Class Members a duty of care that the Affected Class Vehicles did not have a design and/or manufacturing defect;

(e) a declaration that the Defendants, FCA CANADA INC. and FCA US LLC,:

- (i) breached their duty of care to the Plaintiff and putative Class Members;
- (ii) breached express warranties as to the Affected Class Vehicles and are consequently liable to the Plaintiff and putative Class Members for damages;
- (iii) concealed material information from the Plaintiff and putative Class Members as to the Affected Class Vehicles;
- (iv) were negligent in their failure to warn the Plaintiff and putative Class members of the Fuel Pump Defect;

(v) breached implied warranties or conditions of merchantability as to the Affected Class Vehicles and are consequently liable to the Plaintiff and putative Class Members for damages pursuant to sections 18(a),(b) and 56 of the *Sale of Goods Act*, R.S.B.C. 1996 ("SGA"), 410; sections 16(2), (4) and 52 of the *Sale of Goods Act*, RSA 2000, c. S-2; sections 16(1), (2) and 52 of the *Sale of Goods Act*, RSS 1978, c. S-1; sections 16(a), (b) and 54 of *The Sale of Goods Act*, CCSM 2000, c. S10; sections 15(1), (2) and 51 of the *Sale of Goods Act*, RSO 1990, c. S.1; sections 16(a),(c) and 54 of the *Sale of Goods Act*, RSNL 1990, c. S-6 ; sections 17(a),(b) and 54 of the *Sale of Goods Act*, RSNS 1989, c. 408; sections 20(a),(b) and 67 of the *Sale of Goods Act*, RSNB 2016, c. 110; sections 16(a), (b) and 53 of the *Sale of Goods Act*, RSPEI 1988, c. S-1; sections 15(a), (b) and 60 of the *Sale of Goods Act*, RSY 2002, c. 198; sections 18(a),(b) and 60 of the *Sale of Goods Act*, RSNWT 1988, c. S-2; and sections 18(a),(b) and 60 of *the Sale of Goods Act*,

RSNWT (Nu) 1988, c. S-2; and

~~(iv)~~(vi) engaged in unfair practices contrary to sections 4 and 5 of the *Business Practices and Consumer Protection Act*, S.B.C. 2004 (“*BPCPA*”); Sections 5 and 6 of the *Consumer Protection Act*, RSA 2000, c. C-26.3; Sections 6 and 7 of *The Consumer Protection and Business Practices Act*, SS, 2013, c C-30.2; Sections 2 and 3 of *The Business Practices Act*, CCSM c B120; Sections 14(1) and (2) of the *Consumer Protection Act*, 2002, SO 2002, c 30, Sch A and Section 4 (1) of the *Consumer Product Warranty and Liability Act*, SNB 1978, c C-18.1, and are consequently liable to the Plaintiff and putative Class Members for damages;

~~(d)~~(f) a declaration that it is not in the interests of justice to require that notice be given, where applicable, under the *BPCPA*; *Consumer Protection Act*, RSA 2000, c. C-26.3; *The Consumer Protection and Business Practices Act*, SS, 2013, cC-30.2; *The Business Practices Act*, CCSM c B120; *Consumer Protection Act*, 2002, SO 2002, c 30, Sch A; *Consumer Product Warranty and Liability Act*, and SNB 1978, c C-18.1, and waiving any such applicable notice provisions;

~~(e)~~(g) an Order for the statutory remedies available under the *BPCPA*; *Consumer Protection Act*, RSA 2000, c. C-26.3; *The Consumer Protection and Business Practices Act*, SS, 2013, c C-30.2; *The Business Practices Act*, CCSM c B120; *Consumer Protection Act*, 2002, SO 2002, c 30, Sch A; *Consumer Product Warranty and Liability Act*, SNB 1978, c C-18.1, including damages, cancellation and/or rescission of the purchase and/or lease of the Affected Class Vehicles;

~~(f)~~(h) an order directing the Defendants, FCA CANADA INC. and/or FCA US LLC, to advertise any adverse findings against them pursuant to section 172(3)© of the *BPCPA*; Section 19 of the *Consumer Protection Act*, RSA 2000, c. C-26.3; Section 93(1)(f) of *The Consumer Protection and Business Practices Act*, SS, 2013, c C-30.2; Section 23(2)(f) of *The Business Practices Act*, CCSM c B120; Section 18(11) of the *Consumer Protection Act*, 2002, SO 2002, c 30, Sch A and Section 15 of the *Consumer Product Warranty and Liability Act*, SNB 1978, c C-18.1;

- (g)(i) a declaration that the Defendants, FCA CANADA INC. and/or FCA US LLC, breached sections 36 and/or 52 of the *Competition Act*, R.S.C 1985, c. C-34 and are consequently liable to the Plaintiff and putative Class Members for damages;
- (h)(j) an order enjoining the Defendants, FCA CANADA INC. and FCA US LLC, from continuing their unlawful and unfair business practices as alleged herein;
- (i)(k) injunctive and/or declaratory relief requiring the Defendants, FCA CANADA INC. and/or FCA US LLC, to recall, repair and/or replace the 3.0L EcoDiesel engine with the defective high-pressure fuel injection pump in the Affected Class Vehicles and/or buy back all Affected Class Vehicles and to fully reimburse and make whole all putative Class Members for all costs and economic losses associated therewith;
- (l) a declaration that the Affected Class Vehicles present a real, imminent and substantial danger and should not be driven until the Defendants, FCA CANADA INC. and/or FCA US LLC, implement a recall repair that actually eliminates this danger, and that until such recall repair is implemented, the Defendants, FCA CANADA INC. and/or FCA US LLC, should provide a rental or "courtesy" car at no cost to putative Class Members;
- (j)(m) an order pursuant to section 29 of the *Class Proceeding Act*, R.S.B.C. 1996, c.50 ("CPA") directing an aggregate assessment of damages;
- (k)(n) costs of notice and administering the plan of distribution of the recovery in this action plus applicable taxes pursuant to section 24 of the CPA;
- (h)(o) damages, including actual, compensatory, incidental, statutory and consequential damages;
- (m)(p) special damages;
- (n)(q) punitive damages;

~~(e)~~(r) costs of investigation pursuant to section 36 of the *Competition Act*;

~~(p)~~(s) pre-judgment and post-judgment interest pursuant to the *Court Order Interest Act*,
R.S.B.C. 1996, c. 79; and

~~(q)~~(t) such further and other relief as to this Honourable Court may seem just.

Part 3: LEGAL BASIS

Jurisdiction

1. There is a real and substantial connection between British Columbia and the facts alleged in this proceeding. The Plaintiff and proposed Class Members plead and rely upon the *Court Jurisdiction and Proceedings Transfer Act*, R.S.B.C. 2003, c.28 (the "CJPTA") in respect of the Defendants. Without limiting the foregoing, a real and substantial connection between British Columbia and the facts alleged in this proceeding exists pursuant to sections 10 (e)(i), (e)(iii)(A)(B), (f), (g), (h) and (i) of the *CJPTA* because this proceeding:

(e)(i) concerns contractual obligations to a substantial extent, were to be performed in British Columbia;

(e)(iii)(A)(B) the contract is for the purchase of property, services or both, for use other than in the course of the purchaser's trade or profession, and resulted from a solicitation of business in British Columbia by or on behalf of the seller;

(f) concerns restitutionary obligations that, to a substantial extent, arose in British Columbia;

(g) concerns a tort committed in British Columbia;

(h) concerns a business carried on in British Columbia; and

- (i) is a claim for an injunction ordering a party to do or refrain from doing anything in British Columbia.

Causes of Action

Negligence

2. The Defendant, FCA, at all material times owed a duty of care to the Plaintiff and putative Class to provide a product that did not have a design defect. The Affected Class Vehicles equipped with the 3.0L EcoDiesel engine with the CP4 fuel pump pose a real and substantial danger of harm or injury to putative Class Members, and damage to the vehicle's fuel injection system, on account of the Fuel Pump Defect.
3. The Defendant, FCA, as the designer, engineer, manufacturer, promoter, marketer and/or distributor of the Affected Class Vehicles and their counterparts, intended for use by ordinary consumers, owed a duty of care to the Plaintiff and putative Class to ensure that the Affected Class Vehicles and their component parts, including the fuel pump, were reasonably safe for use.
4. At all material times, the Defendant, FCA, owed a duty of care to the Plaintiff and putative Class Members and breached that standard of care expected in the circumstances. It knew that its 3.0L EcoDiesel engine with the CP4 fuel pump was not compatible with the lubricity of North American diesel fuel such that normal use of the Affected Class Vehicles causes metal shards to wear off the CP4 fuel pump and disperse throughout and contaminate the vehicle's fuel system, leading to component wear and catastrophic engine failure while the vehicle is in motion, all of which posed a real and substantial danger of harm or injury to vehicle occupants and damage to the vehicle's fuel injection system. Despite such knowledge, the Defendant, FCA, continued to install the 3.0L EcoDiesel engine with the defective CP4 fuel pump in the Affected Class Vehicles.
5. The Defendant, FCA, owed the Plaintiff and putative Class Members a duty to carefully monitor the safety and post-market performance of the 3.0L EcoDiesel engine equipped in the Affected Class Vehicles with the defective CP4 fuel pump. The Defendant, FCA,

had a duty to warn or promptly warn the Plaintiff and putative Class Members that the CP4 fuel pump was not compatible with the lubricity of North American diesel fuel such that normal use of the Affected Class Vehicles causes metal shards to wear off the CP4 fuel pump and disperse throughout and contaminate the vehicle's fuel system, leading to component wear and catastrophic engine failure while the vehicle is in motion, all of which posed a real and substantial danger of harm or injury to vehicle occupants, damage to the vehicle's fuel injection system and component parts, and which it failed to do.

6. The circumstances of the Defendant, FCA, being in the business of designing, manufacturing and placing the Affected Class Vehicles and their component parts, including the vehicle's fuel pump, into the Canadian stream of commerce are such that the Defendant, FCA, is in a position of legal proximity to the Plaintiff and putative Class Members, and therefore are under an obligation to be fully aware of safety when designing, manufacturing, assembling and selling a product such as the Affected Class Vehicles equipped with the 3.0L EcoDiesel engine with the defective CP4 fuel pump that was not compatible with the lubricity of North American diesel fuel.
7. It was reasonably foreseeable that a failure by the Defendant, FCA, to design, manufacturer and/or install a fuel pump in the 3.0L EcoDiesel engine equipped in the Affected Class Vehicles that was compatible with the lubricity of North America diesel fuel, and thereafter to monitor the performance of the fuel pump following market introduction, and take corrective measures when required, would lead to catastrophic engine failure and cause harm to the Plaintiff and putative Class Members
8. The Defendant, FCA, through its employees, officers, directors, and agents, failed to meet the reasonable standard of care or conduct expected of a vehicle manufacturer in the circumstances in that:
 - (a) it knew, or ought to have known, about the Fuel Pump Defect in the Affected Class Vehicles and should have timely warned the Plaintiff and putative Class Members;
 - (b) it designed, developed, manufactured, tested, assembled, marketed, advertised, distributed, supplied and/or sold vehicles equipped with a 3.0L EcoDiesel engine

with a defective CP4 fuel pump which was not compatible with the lubricity of North American diesel fuel such that normal use of the Affected Class Vehicles causes metal shards to wear off the CP4 fuel pump and disperse throughout and contaminate the vehicle's fuel system, leading to component wear and catastrophic engine failure while the vehicle is in motion, all of which posed a real and substantial danger of harm or injury to vehicle occupants and damage to the vehicle's fuel injection system and component parts;

- (c) it failed to timely warn the Plaintiff, putative Class Members and/or consumers about the Fuel Pump Defect in the Affected Class Vehicles causing them to stall while in motion, which posed a serious safety hazard to drivers and passengers;
- (d) it failed to change the design, manufacture and/or assembly of the 3.0L EcoDiesel engine with the defective CP4 fuel pump in the Affected Class Vehicles in a reasonable and timely manner;
- (e) it failed to provide a safer alternative design for a high-pressure fuel injection system in the Affected Class vehicles that could withstand North American diesel fuel specifications in terms of lubrication and water content that relied on a slide foot design rather than a cam-roller design;
- (f) it failed to properly inspect and test the 3.0L EcoDiesel engine with the defective CP4 fuel pump in the Affected Class Vehicles;
- (g) it knew, or ought to have known, about the Fuel Pump Defect in the Affected Class Vehicles but failed to disclose it;
- (h) it failed to timely issue and implement safety, repair and/or replacement recalls of the Affected Class Vehicles with a defective CP4 fuel pump;
- (i) it failed to adequately perform a recall query as to the Fuel Pump Defect in Affected Class Vehicles;

- (j) it failed to determine whether its remedy was adequate to fix the Fuel Pump Defect in the Affected Class Vehicles;
- (k) it failed to determine whether its recall properly included all defective and noncompliant vehicles;
- (l) it failed to adequately determine the timeliness and/or availability of its remedy to fix the Fuel Pump Defect in Affected Class Vehicles;
- (m) it failed to determine whether its recall remedy appropriately addressed the safety risk posed by the Fuel Pump Defect in the Affected Class Vehicles and provided complete relief to the Plaintiff and Class Members, including all loss, expense and/or damage incurred;
- (n) it failed, and continued to fail, to offer a non-defective recall repair for the Fuel Pump Defect as its recall remedy failed to remove the Fuel Pump Defect from the Affected Class Vehicles;
- (~~h~~)(o) the Fuel Pump Defect presented a serious safety hazard to drivers and passengers as the Affected Class Vehicles' could stall while in motion as a result of metal shards wearing off the CP4 fuel pump and contaminating the vehicle's fuel system, leading to component wear and catastrophic engine failure;
- (~~h~~)(p) notwithstanding that it foresaw personal injury and the loss of life and property of the drivers and passengers in the Affected Class vehicles, it failed or failed to promptly eliminate or correct the Fuel Pump Defect; and
- (~~h~~)(q) it failed to exercise reasonable care and judgment in matters of design, manufacture, materials, workmanship and/or quality of product which would reasonably be expected of them as an automobile manufacturer.

9. As a result of the Fuel Pump Defect in the Affected Class Vehicles by reason of the Defendant's, FCA's, negligence and its failure to disclose and/or adequately warn of the

Fuel Pump Defect, the Plaintiff and putative Class Members have suffered damages and will continue to suffer damages. The value of each of the Affected Class Vehicles is reduced or diminished. The Plaintiff and each putative Class Member must expend the time to have his/her vehicle repaired and be without their vehicle. The Defendant, FCA, should compensate the Plaintiff and each putative Class Member for their incurred out-of-pocket expenses for, *inter alia*, repair, towing, alternative transportation and vehicle payments as a result of the Fuel Pump Defect.

Breach of Express Warranty

10. The Plaintiff and putative Class Members hereby incorporate by reference the allegations contained in the preceding paragraphs of this Amended Notice of Civil Claim.
11. As an express warrantor, manufacturer, supplier and/or merchant, the Defendant, FCA, had certain obligations to conform the 3.0L EcoDiesel engine equipped in the Affected Class Vehicles with the defective CP4 fuel pump to its express warranties.
12. The Defendant, FCA, marketed, distributed and/or sold the Affected Class Vehicles in Canada, including the Province of British Columbia, as safe and reliable vehicles through independent retail dealers and/or authorized dealerships. Such representations formed the basis of the bargain in the Plaintiff's and putative Class Members' decisions to purchase and/or lease the Affected Class Vehicles.
13. When the Plaintiff and putative Class Members purchased and/or leased their vehicles equipped with the 3.0L EcoDiesel engine (either as new vehicles or as used vehicles with remaining warranty coverage), the Defendant, FCA, expressly warranted under its warranty that it would cover all parts and labour needed to repair any item on the diesel vehicle when it left the manufacturing plant that is defective in material, workmanship or factory preparation. The Defendant, FCA, provided an express 3 year/60,000 kilometer written basic warranty on the Affected Class Vehicles it manufactured.
14. Further, the Defendant's FCA's, Powertrain Limited Warranty on diesel engines in the Affected Class Vehicles covers the cost of all parts and labour needed to repair a 3.0L

EcoDiesel engine component that is defective in workmanship and materials, including all internal parts and fuel injection pump and injectors for 5 years/100,000 kilometers.

15. The warranties of the Defendant, FCA, formed a basis of the bargain that was reached when the Plaintiff and putative Class Members purchased and/or leased the Affected Class Vehicles.
16. The Fuel Pump Defect at issue in this litigation was present at the time the Affected Class Vehicles equipped with the 3.0L EcoDiesel engine with the CP4 fuel pump were sold and/or leased to Plaintiff and putative Class Members.
17. The Defendant, FCA, breached its express warranties (and continue to breach these express warranties) because it did not and have not corrected the Fuel Pump Defect in the Affected Class Vehicles equipped with the 3.0L EcoDiesel engine with the CP4 fuel pump.
18. Pursuant to its express warranties, the Defendant, FCA, was obligated to correct any fuel pump defect in the 3.0L EcoDiesel engine in the Affected Class Vehicles owned or leased by the Plaintiff and putative Class Members.
19. Although the Defendant, FCA, was obligated to correct the Fuel Pump Defect with the 3.0L EcoDiesel engine, none of the purported, attempted fixes to the Fuel Pump Defect are adequate under the terms of the warranty, as they did not cure the Fuel Pump Defect.
20. The Defendant, FCA, has failed and/or refused to conform the 3.0L EcoDiesel engine equipped in the Affected Class Vehicles with the defective CP4 fuel pump to its express warranties. The Defendant's, FCA's, conduct, as averred to herein, has voided any attempt on its part to disclaim liability for its actions.
21. In particular, the Defendant, FCA, breached its express warranties by:
 - (a) knowingly providing the Plaintiff and putative Class Members with Affected Class Vehicles containing defects in material that were never disclosed to the Plaintiff and

putative Class Members;

- (b) failing to repair or replace the Affected Class Vehicles' 3.0L EcoDiesel engine with the CP4 fuel pump at no cost within the warranty period;
 - (c) ignoring, delaying responses to and denying warranty claims in bad faith; and
 - (d) supplying products and materials that failed to conform to its representations.
22. The Plaintiff and putative Class Members have performed each and every duty required of them under the terms of the warranties, except as may have been excused or prevented by the conduct of the Defendant, FCA, or by operation of law in light of the Defendant's, FCA's, conduct as described herein.
23. The Plaintiff and putative Class Members have given the Defendant, FCA, a reasonable opportunity to cure its breach of express warranties or, alternatively, were not required to do so because such an opportunity would be unnecessary and futile given that the repairs and/or replacements offered by the Defendant, FCA, can neither cure the Fuel Pump Defect in the Affected Class Vehicles nor resolve the incidental and consequential damages flowing therefrom.
24. The Defendant, FCA, received timely notice regarding the Fuel Pump Defect from the Plaintiff and putative Class Members when they brought their vehicles to their dealerships. The Defendant, FCA, also received notice through complaints made by other consumers, to, *inter alia*, NHTSA and/or Transport Canada. Notwithstanding such notice, the Defendant, FCA, has failed and refused to offer an effective remedy.
25. In its capacity as a manufacturer, supplier and/or warrantor, and by the conduct described herein, any attempt by the Defendant, FCA, to limit its express warranties in a manner that would enforce the warranty period limit would be unconscionable. The Defendant's, FCA's warranties were adhesive, and did not permit negotiation, or the inclusion of design defects. The Defendant, FCA, possessed superior knowledge of the Fuel Pump Defect in the 3.0L EcoDiesel engine prior to offering the vehicles equipped with these engines for sale. The Defendant, FCA, concealed and did not disclose or remedy the Fuel Pump

Defect prior to sale (or afterward). Any effort to otherwise limit liability for the design defect is null and void.

26. Further, because the Defendant, FCA, has not been able remedy the Fuel Pump Defect, the limitation on remedies included in the warranty fails its essential purpose and is null and void.
27. The Plaintiff and putative Class Members have suffered damages caused by the Defendant's, FCA's, breach of its express warranties and are entitled to recover damages, including but not limited to diminution of value.

Breach of the Implied Warranty or Condition of Merchantability pursuant to SGA and Parallel Provincial Sale of Goods Legislation

28. The Plaintiff and putative Class Members hereby incorporate by reference the allegations contained in the preceding paragraphs of this Amended Notice of Civil Claim.
29. The Defendant, FCA, is a "seller" with respect to motor vehicles within the meaning of the SGA, *Sale of Goods Act*, RSA 2000, c. S-2; *Sale of Goods Act*, RSS 1978, c. S-1; *The Sale of Goods Act*, CCSM 2000, c. S10; *Sale of Goods Act*, RSO 1990, c. S.1; *Sale of Goods Act*, RSNL 1990, c. S-6 ; *Sale of Goods Act*, RSNS 1989, c. 408; *Sale of Goods Act*, RSNB 2016, c. 110; *Sale of Goods Act*, RSPEI 1988, c. S-1; *Sale of Goods Act*, RSY 2002, c. 198; *Sale of Goods Act*, RSNWT 1988, c. S-2; and *Sale of Goods Act*, RSNWT (Nu) 1988, c. S-2, pursuant to its agency relationship with its authorized dealers, distributors, resellers, retailers and/or intermediaries..
30. The Defendant, FCA, is and was at all relevant times a seller with respect to Affected Class Vehicles equipped with the 3.0L EcoDiesel engine with the defective CP4 fuel pump. The Defendant, FCA, directly sold and marketed vehicles equipped with the 3.0L EcoDiesel engine with the defective CP4 fuel pump to customers through authorized dealers, like those from whom putative Class Members bought or leased their vehicles, for the intended purpose of consumers purchasing the vehicles. The Defendant, FCA, knew that the Affected Class Vehicles equipped with a 3.0L Ecodiesel engine with the

defective CP4 fuel pump would and did pass unchanged from the authorized dealers to putative Class Members, with no modification to the engine and/or fuel pump.

31. The CP4 fuel pumps in the Affected Class Vehicles are inherently defective in that they are particularly incompatible with North American diesel fuel such that the normal use of the Affected Class Vehicles causes metal shards to wear off the fuel pump and disperse throughout the vehicle's fuel injection system, leading to catastrophic engine failure, (often times while the vehicle is in motion, causing a moving stall and subsequent inability to restart the vehicle), thereby causing an increased likelihood of serious harm or injury to vehicle occupants.
32. A warranty that the Affected Class Vehicles were in merchantable condition was implied by law pursuant to sections 18(a) and/or (b) of the *SGA*, sections 16(2) and/or (4) of the *Sale of Goods Act*, RSA 2000, c. S-2; sections 16(1) and (2) of the *Sale of Goods Act*, RSS 1978, c. S-1; sections 16(a) and/or (b) of *The Sale of Goods Act*, CCSM 2000, c. S10; sections 15(1) and/or (2) of the *Sale of Goods Act*, RSO 1990, c. S.1; sections 16(a) and/or (c) of the *Sale of Goods Act*, RSNL 1990, c. S-6 ; sections 17(a) and/or (b) of the *Sale of Goods Act*, RSNS 1989, c. 408; sections 20(a) and/or (b) of the *Sale of Goods Act*, RSNB 2016, c. 110; sections 16(a) and/or (b) of the *Sale of Goods Act*, RSPEI 1988, c. S-1; sections 15(a) and/or (b) of the *Sale of Goods Act*, RSY 2002, c. 198; sections 18(a) and/or (b) of the *Sale of Goods Act*, RSNWT 1988, c. S-2; and sections 18(a) and (b) of the *Sale of Goods Act*, RSNWT (Nu) 1988, c. S-2.
33. The Defendant, FCA, marketed, distributed and/or sold the Affected Class Vehicles in Canada, including the Province of British Columbia, as safe and reliable vehicles through independent retail dealers and/or authorized dealerships. Such representations formed the basis of the bargain in putative Class Members' decisions to purchase and/or lease the Affected Class Vehicles.
34. Affected Class Vehicles equipped with the 3.0L EcoDiesel engine with the CP4 fuel pump were defective at the time they left the possession of the Defendant, FCA. The Defendant, FCA, knew of this defect at the time these transactions occurred. Thus, vehicles equipped with the 3.0L EcoDiesel engine with the CP4 fuel pump, when sold and at all times

thereafter, were not in merchantable condition or quality and were not fit for their ordinary intended purpose.

35. The Plaintiff and putative Class Members purchased and/or leased the Affected Class Vehicles from the Defendant, FCA, through their subsidiaries, authorized agents for retail sales, through private sellers or were otherwise expected to be the eventual purchasers and/or lessees of the Affected Class Vehicles when bought and/or leased from a third party. At all relevant times, the Defendant, FCA, was the manufacturer, distributor, warrantor and/or seller of the Affected Class Vehicles. As such, there existed privity and/or vertical privity of contract between the Plaintiff and putative Class Members and the Defendant, FCA, as to its Affected Class Vehicles. Alternatively, privity of contract need not be established nor is it required because the Plaintiff and putative Class Members are intended third-party beneficiaries of contracts between the Defendant, FCA, and its resellers, authorized dealers and/or distributors and, specifically, of the Defendant's FCA's, implied warranties.
36. The Defendant's , FCA's, resellers, authorized dealers and/or distributors are intermediaries between the Defendant, FCA, and consumers. These intermediaries sell the Affected Class Vehicles to consumers and are not, themselves, consumers of the Affected Class Vehicles and, therefore, have no rights against the Defendant, FCA, with respect to the Plaintiff's and putative Class Members' acquisition of the Affected Class Vehicles. The Defendant's, FCA's, warranties were designed to influence consumers who purchased and/or leased the Affected Class Vehicles.
37. The Defendant, FCA, knew or had reason to know of the specific use for which the Affected Class Vehicles were purchased or leased.
38. As a result of the Fuel Pump Defect, the Affected Class Vehicles were not in merchantable condition when sold and are not fit for the ordinary purpose of providing safe and reliable transportation.
39. The Defendant, FCA, knew about the Fuel Pump Defect in the Affected Class Vehicles, allowing it to cure its breach of warranty if they chose.

40. At all times that the Defendant, FCA, warranted and sold its Affected Class Vehicles, it knew or should have known that its warranties were false and yet it did not disclose the truth or stop manufacturing or selling its Affected Class Vehicles and, instead, continued to issue false warranties and continued to insist the products were safe. The Affected Class Vehicles were defective when the Defendant, FCA, delivered them to its resellers, authorized dealers and/or distributors which sold the Affected Class Vehicles and the Affected Class Vehicles were, therefore, still defective when they reached Plaintiff and putative Class Members.

41. The Defendant's, FCA's, attempt to disclaim or limit the implied warranty of merchantability vis-à-vis the Plaintiff, putative Class Members and/or consumers is unconscionable and unenforceable. Specifically, the Defendant's, FCA's, warranty limitation is unenforceable because it knowingly sold and/or leased a defective product without informing the Plaintiff, putative Class Members and/or consumers about the Fuel Pump Defect in the Affected Class Vehicles. The time limits contained in the Defendant's, FCA's, warranty periods were also unconscionable and inadequate to protect the Plaintiff and putative Class Members. Among other things, the Plaintiff and putative Class Members had no meaningful choice in determining these time limitations, the terms of which unreasonably favored the Defendant, FCA. A gross disparity in bargaining power existed between the Defendant, FCA, and the Plaintiff and putative Class Members, and the Defendant, FCA, knew that the Affected Class Vehicles were equipped with a 3.0L EcoDiesel engine with a defective CP4 fuel pump which was not compatible with the lubricity of North American diesel fuel such that normal use of the Affected Class Vehicles causes metal shards to wear off the CP4 fuel pump and disperse throughout and contaminate the vehicle's fuel system, leading to component wear and catastrophic engine failure while the vehicle is in motion, all of which posed a real and substantial danger of harm or injury to vehicle occupants.

42. The Plaintiff and putative Class Members have complied with all obligations under the warranty or otherwise have been excused from performance of said obligations as a result of the Defendant's, FCA's, conduct alleged herein. Affording the Defendant, FCA, a reasonable opportunity to cure its breach of written warranties, therefore, would be unnecessary and futile.

43. As a direct and proximate result of the Defendant's, FCA's, breach of implied warranties or conditions of merchantability, the Plaintiff and putative Class Members have suffered loss, diminution and/or damage as a result of the Fuel Pump Defect in the Affected Class Vehicles pursuant to sections 56 of the *SGA*, section 52 of the *Sale of Goods Act*, RSA 2000, c. S-2; section 52 of the *Sale of Goods Act*, RSS 1978, c. S-1; section 54 of *The Sale of Goods Act*, CCSM 2000, c. S10; section 51 of the *Sale of Goods Act*, RSO 1990, c. S.1; section 54 of the *Sale of Goods Act*, RSNL 1990, c. S-6 ; section 54 of the *Sale of Goods Act*, RSNS 1989, c. 408; section 67 of the *Sale of Goods Act*, RSNB 2016, c. 110; section 53 of the *Sale of Goods Act*, RSPEI 1988, c. S-1; section 60 of the *Sale of Goods Act*, RSY 2002, c. 198; section 60 of the *Sale of Goods Act*, RSNWT 1988, c. S-2; and section 60 of the *Sale of Goods Act*, RSNWT (Nu) 1988, c. S-2.

Violation of *BPCPA* and Parallel Provincial Consumer Protection Legislation

44. The Plaintiff and putative Class Members in British Columbia hereby incorporate by reference the allegations contained in the preceding paragraphs of this Amended Notice of Civil Claim.
45. The Defendant, FCA, is in British Columbia for the purposes of the *BPCPA*, and in provinces with parallel consumer protection legislation, as described in Schedule "A".
46. The Affected Class Vehicles are consumer "goods" within the meaning of section 1(1) of the *BPCPA*, and in provinces with parallel consumer protection legislation, as described in Schedule "A".
47. Putative Class Members in British Columbia who purchased and/or leased the Affected Class Vehicles primarily for personal, family or household purposes, and not for resale or for the purposes of carrying on business, are "consumers" within the meaning of section 1(1) of the *BPCPA*, and provinces with parallel consumer protection legislation, as described in Schedule "A".
48. The purchase and/or lease of the Affected Class Vehicles by putative Class Members in British Columbia for personal, family or household purposes, and not for resale or for

carrying on business constitutes a “consumer transaction” within the meaning of section 1(1) of the *BPCPA*, and provinces with parallel consumer protection legislation, as described in Schedule “A”.

49. The Defendant, FCA, is a “supplier” within the meaning of section 1(1) of the *BPCPA*, and in provinces with parallel consumer protection legislation, as described in Schedule “A”, as it carried on business in British Columbia and who in the course of business participated in a consumer transaction by: (i) supplying goods to a consumer, or (ii) soliciting, offering, advertising or promoting with respect to a consumer transaction, whether or not privity of contract exists between that person and the consumer, and includes an assignee of, any rights or obligations of the supplier under the *BPCPA*. The Defendant, FCA, is the vehicle manufacturer of the Affected Class Vehicles and distributes, markets and/or supplies such vehicles to consumers including proposed Class Members in British Columbia. At all relevant times, the Defendant, FCA, was a supplier and/or seller of the Affected Class Vehicles as its resellers, authorized dealers and/or distributors were acting as the agents of the Defendant, FCA.

50. By failing to disclose and actively concealing the Fuel Pump Defect in the Affected Class Vehicles, the Defendant, FCA, engaged in unfair and deceptive trade practices prohibited by sections 4 and 5 of the *BPCPA*, and provinces with parallel consumer protection legislation, as described in Schedule “A”. The Defendant, FCA, knew that the Affected Class Vehicles equipped with a 3.0L EcoDiesel engine with a defective CP4 fuel pump were not compatible with the lubricity of North American diesel fuel such that normal use of the Affected Class Vehicles causes metal shards to wear off the CP4 fuel pump and disperse throughout and contaminate the vehicle’s fuel system, leading to component wear and catastrophic engine failure while the vehicle is in motion, all of which presented a real and substantial danger of harm or injury to vehicle occupants and damage to the vehicle’s fuel injection system. The Defendant, FCA, and made misleading statements or omissions concerning the Fuel Pump Defect, but yet failed to adequately warn consumers.

51. As alleged herein, the Defendant, FCA, made misleading representations and omissions concerning the quality, reliability, durability, performance and/or safety of the Affected

Class Vehicles.

52. In purchasing and/or leasing the Affected Class Vehicles, putative Class Members were deceived by the Defendant's, FCA's, failure to disclose its knowledge of the Fuel Pump Defect and associated safety risk.
53. In particular, the Defendant, FCA, engaged in a pattern of unfair or deceptive acts or practices in failing to disclose to putative Class Members that the Affected Class Vehicles are prone to catastrophic fuel pump failure which causes them to stall while in motion with a subsequent inability to restart, resulting in a costly high-pressure fuel injection system repair and/or replacement process that the Defendant, FCA, will not cover, as follows.
 - (a) failing to disclose that the Affected Class Vehicles equipped with the 3.0L EcoDiesel engine with the CP4 fuel pump was not of a particular standard, quality, or grade;
 - (b) failing to disclose before, during and/or after the time of purchase, lease and/or repair, any and all known material defects or material nonconformity of the Affected Class Vehicles, including the Fuel Pump Defect;
 - (c) failing to disclose at the time of purchase and/or lease that the Affected Class Vehicles, including the 3.0L EcoDiesel engine with the CP4 fuel pump, were not in good working order, defective, not fit for their intended, and ordinary purpose, and created a real and substantial danger or harm to occupants of the Affected Class Vehicles, and damage to the vehicle's fuel injection system and component parts;
 - (d) failing to give adequate warnings and/or notices regarding the use, defects, and problems with the 3.0L EcoDiesel engine with the defective CP4 fuel pump in the Affected Class Vehicles' to consumers who purchased and/or leased the Affected Class Vehicles, even though the Defendant, FCA, possessed exclusive knowledge of the inherent defect in the 3.0L EcoDiesel engine with the CP4 fuel pump before and at the time of purchase and/or lease;
 - (e) failing to disclose, either through warnings and/or recall notices, and/or actively concealing, the fact that the 3.0L EcoDiesel engine with the CP4 fuel pump

equipped in the Affected Class Vehicles was defective, even though the Defendant, FCA, knew about the Fuel Pump Defect; and

- (f) representing that the Fuel Pump Defect in the Affected Class Vehicles would be covered under its warranty program.

54. In purchasing and/or leasing the Affected Class Vehicles, putative Class Members in British Columbia were deceived by the Defendant's, FCA's, failure to disclose its exclusive knowledge that the CP4 fuel pump in the Affected Class Vehicles was not compatible with the lubricity of North American diesel fuel such that normal use of the Affected Class Vehicles causes metal shards to wear off the CP4 pump and disperse throughout and contaminate the vehicle's fuel system, leading to component wear and catastrophic engine failure while the vehicle is in motion, all of which posed a real and substantial danger of harm or injury to vehicle occupants.

55. By failing to disclose and actively concealing the Fuel Pump Defect, the Defendant, FCA, engaged in unfair or deceptive acts or practices prohibited by sections 4 and 5 of the *BPCPA*, and parallel provincial consumer protection legislation, as described in Schedule "A".

56. Further, as alleged herein, the Defendant, FCA, made misleading representations and/or omissions concerning the quality, reliability, durability performance and/or safety of the Affected Class Vehicles equipped with the 3.0L EcoDiesel engine with the defective CP4 fuel pump, by:

- (a) publishing owners' manuals that made materially misleading omissions concerning the effectiveness of the 3.0L EcoDiesel engine with the defective CP4 pump which uniformly omitted any warning to consumers that Affected Class Vehicles were not compatible with the lubricity of North American diesel fuel such that normal use of the Affected Class Vehicles causes metal shards to wear off the CP4 pump and disperse throughout and contaminate the vehicle's fuel system, leading to component wear and catastrophic engine failure while the vehicle is in motion, all of which posed a real and substantial danger of harm or injury to vehicle occupants;

- (b) advertisements which uniformly omitted any information about the Fuel Pump Defect and which misled consumers into believing that the 3.0L EcoDiesel engine with the defective CP4 pump would function properly; and
- (c) emphasizing and extolling in brochures and press releases that the Affected Class Vehicles equipped with the 3.0L EcoDiesel engine with the defective CP4 pump were dependable, long-lasting, of the highest quality and with exceptional capability.

57. The Defendant's, FCA's, conduct as alleged herein was, and is, in violation of sections 4 and 5 of the *BPCPA*, and parallel provincial consumer protection legislation, as described in Schedule "A", in particular, by:

- (a) representing that the Affected Class Vehicles, including its 3.0L EcoDiesel engine with the CP4 fuel pump, was defect-free and did not pose a safety hazard, which it did not;
- (b) representing that the Affected Class Vehicles, including its 3.0L EcoDiesel engine with the defective CP4 fuel pump, was of a particular standard, quality or grade, when they were not;
- (c) advertising the Affected Class Vehicles, including its 3.0L EcoDiesel engine with the defective CP4 fuel pump, with the intent not to sell them as advertised; and
- (d) representing that the Affected Class Vehicles, including including its 3.0L EcoDiesel engine with the defective CP4 fuel pump, have been supplied in accordance with a previous representation as to quality, reliability, durability, performance and/or safety, when they have not.

58. In purchasing and/or leasing the Affected Class Vehicles, putative Class Members in British Columbia were deceived by the Defendant's, FCA's, failure to disclose its exclusive knowledge of the Fuel Pump Defect and/or its representations made as to the quality, reliability, durability, performance and/or safety of the Affected Class Vehicles in its sales

brochure materials, manuals, press releases and/or websites.

59. The Defendant, FCA, intentionally and knowingly misrepresented and omitted material facts regarding its Affected Class Vehicles, specifically regarding the Fuel Pump Defect, with an intent to mislead putative Class Members.
60. In purchasing and/or leasing the Affected Class Vehicles, putative Class Members were deceived by the Defendant's, FCA's, failure to disclose its knowledge of the Fuel Pump Defect and associated safety risk.
61. Putative Class Members had no way of knowing of the Defendant's, FCA's, representations were false, misleading and incomplete or knowing the true nature of the Fuel Pump Defect in the Affected Class Vehicles. As alleged herein, the Defendant, FCA, engaged in a pattern of deception in the face of a known fuel pump defect in the Affected Class Vehicles. Putative Class Members did not, and could not, unravel the Defendant's, FCA's, deception on their own.
62. The Defendant, FCA, knew, or should have known, that its conduct violated sections 4 and 5 of the *BPCPA*, and parallel provincial consumer protection legislation, as described in Schedule "A".
63. The Defendant, FCA, owed putative Class Members a duty to disclose the truth about the Fuel Pump Defect in the Affected Class Vehicles as it created a serious safety hazard and the Defendant, FCA:
 - (a) possessed exclusive knowledge of the Fuel Pump Defect in the Affected Class Vehicles;
 - (b) intentionally concealed the foregoing from putative Class Members; and/or
 - (c) failed to warn consumers or to publicly admit that the Affected Class Vehicles had a fuel pump defect.

64. The Defendant, FCA, had a duty to disclose that the 3.0L EcoDiesel engine with the CP4 fuel pump equipped in the Affected Class Vehicles was fundamentally flawed as described herein because it created a serious safety hazard and putative Class Members relied on the Defendant's, FCA's, material misrepresentations and omissions regarding the Affected Class Vehicles and the Fuel Pump Defect.
65. The Defendant's, FCA's, conduct proximately caused injuries to putative Class Members that purchased and/or leased the Affected Class Vehicles and suffered harm as alleged herein.
66. Putative Class Members were injured and suffered ascertainable loss, injury-in-fact and/or actual damage as a proximate result of the Defendant's, FCA's, conduct in that putative Class Members incurred costs related the Fuel Pump Defect including repair, service and/or replacement costs, rental car costs and overpaid for their Affected Class Vehicles that have suffered a diminution in value.
67. The Defendant's, FCA's, violations cause continuing injuries to putative Class Members. The Defendant's, FCA's, unlawful acts and practices complained of herein affect the public interest.
68. The Defendant, FCA, knew of the defective CP4 fuel pump in the Affected Class Vehicles and which were materially compromised by the Fuel Pump Defect.
69. The facts concealed and omitted by the Defendant, FCA, from putative Class Members are material in that a reasonable consumer would have considered them to be important in deciding whether to purchase an Affected Class Vehicle or pay a lower price. Had putative Class Members known about the defective nature of the 3.0L EcoDiesel engine with the defective CP4 fuel pump equipped in the Affected Class Vehicles, they would not have purchased and/or leased the Affected Class Vehicles or would not have paid the prices they paid.
70. Putative Class Members' injuries were directly or proximately caused by the Defendant's, FCA's, unlawful and deceptive business practices.

71. As a result of the Defendant's, FCA's, conduct as alleged herein, putative Class Members in British Columbia are entitled to a declaration under section 172(1)(a) of the *BPCPA* that an act or practice engaged in by the Defendant, FCA, in respect to the purchase and/or lease of the Affected Class Vehicles contravenes the *BPCPA*, an injunction under section 172(1)(b) of the *BPCPA* to restrain such conduct and/or damages under section 171 of the *BPCPA*, and to such remedies under parallel provincial consumer protection legislation, as described in Schedule "A".
72. Putative Class Members in British Columbia are entitled, to the extent necessary, a waiver of any notice requirements under section 173(1) the *BPCPA*, and parallel provincial consumer protection legislation, as described in Schedule "A", as a result of the Defendant's, FCA's, failure to disclose and/or actively conceal the Fuel Pump Defect from putative Class Members in British Columbia and its misrepresentations as to the quality, reliability, durability, performance and/or safety of the Affected Class Vehicles.

Breach of the *Competition Act*

73. The Plaintiff and putative Class Members hereby incorporate by reference the allegations contained in the preceding paragraphs of this Amended Notice of Civil Claim.
74. By making representations to the public as to the quality, reliability, durability, performance and/or safety of the Affected Class Vehicles, the Defendant, FCA, breached sections 36 and/or 52 of the *Competition Act*, in that its representations:
 - (a) were made to the public in the form of advertising brochures, statements and/or other standardized statements claiming as to the quality, reliability, durability, performance and/or safety of the Affected Class Vehicles;
 - (b) were made to promote the supply or use of a product or for the purpose of promoting its business interests;
 - (c) stated safety of the Affected Class Vehicles; and

(d) were false and misleading in a material respect.

75. At all relevant times, the Defendant, FCA, was the seller and/or supplier of the Affected Class Vehicles. As such, there existed contractual privity and/or vertical privity of contract between the Plaintiff and putative Class Members and the Defendant, FCA, as to the Affected Class Vehicles as its resellers, authorized dealers and/or distributors at all material times were acting as the agents of the Defendant, FCA.
76. The Defendant, FCA, engaged in unfair competition and unfair or unlawful business practices through the conduct, statements and omissions described herein and by knowingly and intentionally concealing the Fuel Pump Defect in the Affected Class Vehicles from Plaintiff and putative Class Members, along with concealing the safety risks, costs, and monetary damage resulting from the Fuel Pump Defect. The Defendant, FCA, should have disclosed this information because it was in a superior position to know the true facts related to the Fuel Pump Defect and Plaintiff and putative Class Members could not reasonably be expected to learn or discover the true facts related to the Fuel Pump Defect.
77. The Fuel Pump Defect in the Affected Class Vehicles constitutes a safety issue. The Defendant, FCA, knew that the Affected Class Vehicles equipped with a 3.0L EcoDiesel engine with a defective CP4 pump were not compatible with the lubricity of North American diesel fuel such that normal use of the Affected Class Vehicles causes metal shards to wear off the CP4 pump and disperse throughout and contaminate the vehicle's fuel system, leading to component wear and catastrophic engine failure while the vehicle is in motion, all of which posed a real and substantial danger of harm or injury to vehicle occupants, which triggered the Defendant's, FCA's, duty to disclose the safety issue to consumers.
78. These acts and practices have deceived the Plaintiff and putative Class Members. In failing to disclose the Fuel Pump Defect and suppressing other material facts from the Plaintiff and putative Class Members, the Defendant, FCA, breached its duty to disclose these facts, violated the *Competition Act* and caused injuries to the Plaintiff and putative Class Members. The Defendant's, FCA's, omissions and concealment pertained to

information that was material to the Plaintiff and putative Class Members, as it would have been to all reasonable consumers.

79. Further, the Plaintiff and putative Class Members relied upon the Defendant's, FCA's, misrepresentations as to the quality, reliability, durability, performance and/or safety of the Affected Class Vehicles to their detriment in purchasing and/or leasing the Affected Class Vehicles so as to cause loss and/or damage to the Plaintiff and putative Class Members.

80. The Plaintiff and putative Class Members have, therefore, suffered damages and are entitled to recover damages pursuant to section 36(1) and/or 52 of the *Competition Act*.

Tolling of the *Limitation Act*, S.B.C. 2012, c. 13

81. The Plaintiff and putative Class Members had no way of knowing about the Fuel Pump Defect in the Affected Class Vehicles. The Defendant, FCA, concealed its knowledge of the Fuel Pump Defect while continuing to market, sell and/or lease, the Affected Class Vehicles equipped with the 3.0L EcoDiesel engine with the defective CP4 pump.

82. Within the *Limitation Act*, and to equivalent legislative provisions in the rest of Canada as described in Schedule "B", the Plaintiff and putative Class Members could not have discovered through the exercise of reasonable diligence that the Defendant, FCA, was concealing the conduct complained of herein and misrepresenting the true qualities of the Affected Class Vehicles.

83. The Plaintiff and putative Class Members did not know facts that would have caused a reasonable person to suspect or appreciate that there was a defect in the 3.0L EcoDiesel engine with the defective CP4 fuel pump equipped in the Affected Class Vehicles.

84. For these reasons, the *Limitation Act*, and to equivalent legislative provisions in the rest of Canada, as described in Schedule "B", has been tolled by operation of the discovery rule with respect to the claims in this proposed class proceeding.

85. Further, due to Defendant's, FCA's, knowledge and active concealment of the Fuel Pump

Defect throughout the time period relevant to this proposed class proceeding, the *Limitation Act*, and to equivalent legislative provisions in the rest of Canada as described in Schedule "A" has been tolled.

86. Instead of publicly disclosing the Fuel Pump Defect in the Affected Class Vehicles, the Defendant, FCA, kept the Plaintiff and putative Class Members in the dark as to the Fuel Pump Defect and the serious safety hazard it presented.
87. The Defendant, FCA, was under a continuous duty to disclose to the Plaintiff and putative Class Members the existence of the Fuel Pump Defect in the Affected Class Vehicles.
88. The Defendant, FCA, knowingly, affirmatively and actively concealed or recklessly disregarded the true nature, quality and character of the Affected Class Vehicles.
89. As such, the Defendant, FCA, is estopped from relying on the *Limitation Act*, and equivalent legislative provisions in the rest of Canada as described in Schedule "B", in defense of this proposed class proceeding.

Plaintiff's(s') address for service:

Garcha & Company
Barristers & Solicitors
#405 - 4603 Kingsway
Burnaby, BC V5H 4M4
Canada

Fax number address for service (if any):

604-435-4944

E-mail address for service (if any):

none

Place of trial:

Vancouver, BC, Canada

The address of the registry is:

800 Smithe Street
Vancouver, BC V6Z 2E1
Canada

Dated: June 2, 2025



Signature of K.S. Garcha
lawyer for plaintiff(s)

Schedule "A"
Consumer Protection Legislation Across Canada

Province or Territory	Legislation
Alberta	<p><i>Consumer Protection Act</i>, RSA 2000, c. C-26.3</p> <p>"Goods" - Section 1(1)(e)(i); "Consumers" - Section 1(1)(b)(i); "Consumer Transaction" - Section 1(1)(c)(i); "Supplier" - Section 1(1)(i),(ii) and/or (iii); "Unfair Practices" - Sections 5 and 6; Statutory Remedies - Sections 13(1), (2) and 142.1; and Waiver of Notice - Section 7.1(1)</p>
Saskatchewan	<p><i>The Consumer Protection and Business Practices Act</i>, SS 2014, c. C-30.2</p> <p>"Goods" - Section 2(e); "Consumer" - Section 2(b); "Supplier" - Section 2(i); "Unfair Practices" - Sections 6 and 7; and Statutory Remedies - Section 93</p>
Manitoba	<p><i>Consumer Protection Act</i>, CCSM c. C200</p> <p>"Goods" - Section 1; "Consumer" - Section 1; "Consumer Transaction" - Section 1; "Supplier" - Section 1; "Unfair Business Practices" - Sections 2(1) and (3); and Statutory Remedies - 23(2)(a) and (b)</p>
Ontario	<p><i>Consumer Protection Act</i>, 2002, SO 2002, c. 30, Sch. A</p> <p>"Goods" - Section 1; "Consumer" - Section 1; "Supplier" - Section 1; "Unfair Practices"- Sections 14(1) and (2); Statutory Remedies - Sections 18(1) and (2); and Waiver of Notice - Sections 18(3) and (15)</p>

New Brunswick	<p><i>Consumer Product Warranty and Liability Act, SNB 1978, c. C-18.1</i></p> <p>“Consumer Product” - Section 1(1); “Buyer” - Section 1(1); “Contract for the sale or supply of a consumer product” - Section 1(1); and “Seller” - Section 1(1);</p>
---------------	---

Schedule “B”
Limitation Act Legislation Across Canada

Province or Territory	Legislation
Alberta	<i>Limitations Act</i> , RSA 2000, c. L-12
Saskatchewan	<i>The Limitations Act</i> , SS 2004, c. L-16.1
Manitoba	<i>The Limitation of Actions Act</i> , CCSM c. L150
Ontario	<i>Limitations Act</i> , 2002, SO 2002, c. 24, Sch. B
Newfoundland and Labrador	<i>Limitations Act</i> , SNL 1995, c. L-16.1
Nova Scotia	<i>Limitation of Actions Act</i> , SNS 2014, c. 35
New Brunswick	<i>Limitation of Actions Act</i> , SNB 2009, c. L-8.5
Prince Edward Island	<i>Statute of Limitations</i> , RSPEI 1988, c. S-7
Yukon	<i>Limitation of Actions Act</i> , RSY 2002, c. 139
Northwest Territories	<i>Limitation of Actions Act</i> , RSNWT 1988, c. L-8
Nunavut	<i>Limitation of Actions Act</i> , RSNWT (Nu) 1988, c. L-8

**ENDORSEMENT ON ORIGINATING PLEADING OR PETITION FOR SERVICE OUTSIDE
BRITISH COLUMBIA**

There is a real and substantial connection between British Columbia and the facts alleged in this proceeding. The Plaintiff and the Class Members plead and rely upon the *Court Jurisdiction and Proceedings Transfer Act* R.S.B.C. 2003 c.28 (the “*CJPTA*”) in respect of these Defendants. Without limiting the foregoing, a real and substantial connection between British Columbia and the facts alleged in this proceeding exists pursuant to sections 10(e)(i), (iii)(a) & (b), (f), (g), (h) and (l) of the *CJPTA* because this proceeding:

(e)(i) concerns contractual obligations to a substantial extent, were to be performed in British Columbia:

(e) (iii)(a) & (b) the contract is for the purchase of property, services or both, for use other than in the course of the purchaser’s trade or profession, and resulted from a solicitation of business in British Columbia by or on behalf of the seller;

(f) concerns restitutionary obligations that, to a substantial extent, arose in British Columbia;

(g) concerns a tort committed in British Columbia;

(h) concerns a business carried on in British Columbia;

(i) is a claim for an injunction ordering a party to do or refrain from doing anything in British Columbia.

Appendix

[The following information is provided for data collection purposes only and is of no legal effect.]

Part 1: CONCISE SUMMARY OF NATURE OF CLAIM:

The within proposed multi-jurisdictional class proceeding involves 2014-2020 Jeep Grand Cherokee, 2021-2023 Jeep Wrangler and Gladiator, 2014-2020 and 2022-2023 ~~and~~ Dodge Ram 1500 diesel vehicles designed, manufactured, assembled, tested, marketed, distributed, supplied, leased and/or sold by the Defendants, FCA CANADA INC. and FCA US LLC, in Canada equipped with a 3.0L EcoDiesel engine with a defective high-pressure fuel injection pump incompatible with the lubricity of North American diesel fuel. The fuel pump has a fragile and unstable design, which causes metal parts to rub against each other such that the friction generates metal shavings that contaminate the fuel system, leading to catastrophic engine failure, all of which poses a real and substantial danger of harm or injury to vehicle occupants and damage to the vehicle's fuel system and components. The Defendants,' FCA CANADA INC.'s and FCA US LLC's, recall remedy is inadequate to fix the Fuel Pump Defect and fails to fully reimburse putative Class Members of all out-of-pocket repair costs, including catastrophic failure and replacement of fuel system, engine component parts and/or the engine itself. The recall remedy did not remove the Fuel Pump Defect in the Affected Class Vehicles.

Part 2: THIS CLAIM ARISES FROM THE FOLLOWING:

A personal injury arising out of:

- motor vehicle accident
- medical malpractice
- another cause

A dispute concerning:

- contaminated sites
- construction defects
- real property (real estate)
- personal property
- the provision of goods or services or other general commercial matters
- investment losses
- the lending of money
- an employment relationship
- a will or other issues concerning the probate of an estate
- a matter not listed here

Part 3: THIS CLAIM INVOLVES:

- a class action
- maritime law
- aboriginal law
- constitutional law
- conflict of laws
- none of the above

[] do not know

Part 4:

1. *Class Proceedings Act*, R.S.B.C. 1996, c. 50
2. *Court Jurisdiction and Proceedings Transfer Act*, R.S.B.C. 2003 c. 28
3. *Business Practices and Consumer Protection Act*, S.B.C. 2004; *Consumer Protection Act*, RSA 2000, c. C-26.3; *The Consumer Protection and Business Practices Act*, SS, 2014, c C-30.2; *The Business Practices Act*, CCSM c B120; *Consumer Protection Act*, 2002, SO 2002, c 30, Sch A; *Consumer Product Warranty and Liability Act*, and SNB 1978, c C-18.1
4. *Sale of Goods Act*, R.S.B.C 1996, c. 410; *Sale of Goods Act*, RSA 2000, c. S-2; *Sale of Goods Act*, RSS 1978, c. S-1; *The Sale of Goods Act*, CCSM 2000, c. S10; *Sale of Goods Act*, RSO 1990, c. S.1; *Sale of Goods Act*, RSNL 1990, c. S-6 ; *Sale of Goods Act*, RSNS 1989, c. 408; *Sale of Goods Act*, RSNB 2016, c. 110; *Sale of Goods Act*, RSPEI 1988, c. S-1; *Sale of Goods Act*, RSY 2002, c. 198; *Sale of Goods Act*, RSNWT 1988, c. S-2; and *Sale of Goods Act*, RSNWT (Nu) 1988, c. S-2
5. *Motor Vehicle Safety Act* , R.S.C. 1993, c.16, *Motor Vehicle Safety Regulations, C.R.C. c.1038*
6. 49 U.S. Code 301 - *Motor Vehicle Safety Act*
7. *Canadian Environmental Protection Act*, 1999 S.C. 1999. c.33
8. *Court Order Interest Act*, R.S.B.C., c. 79
9. *Competition Act*, R.S.C 1985, c. C-34
10. *Limitation Act*, S.B.C. 2012, c.13; *Limitations Act*, RSA 2000, c. L-12; *The Limitations Act*, SS 2004, c. L-16.1; *The Limitations Act*, SS 2004, c. L-16.1; *The Limitation of Actions Act*, CCSM c. L150; *Limitations Act*, 2002, SO 2002, c. 24, Sch. B; *Limitations Act*, SNL 1995, c. L-16.1; *Limitation of Actions Act*, SNS 2014, c. 35; *Limitation of Actions Act*, SNB 2009, c. L-8.5; *Statute of Limitations*, RSPEI 1988, c. S-7; *Limitation of Actions Act*, RSY 2002, c. 139; *Limitation of Actions Act*, RSNWT 1988, c. L-8; *Limitation of Actions Act*, RSNWT (Nu) 1988, c. L-8
11. *Crown Liability and Proceedings Act*, RSC 1985, c. c-50

[] do not know

Part 4:

1. *Class Proceedings Act*, R.S.B.C. 1996, c. 50
2. *Court Jurisdiction and Proceedings Transfer Act*, R.S.B.C. 2003 c. 28
3. *Business Practices and Consumer Protection Act*, S.B.C. 2004; *Consumer Protection Act*, RSA 2000, c. C-26.3; *The Consumer Protection and Business Practices Act*, SS, 2014, c C-30.2; *The Business Practices Act*, CCSM c B120; *Consumer Protection Act*, 2002, SO 2002, c 30, Sch A; *Consumer Product Warranty and Liability Act*, and SNB 1978, c C-18.1
4. *Sale of Goods Act*, R.S.B.C 1996, c. 410; *Sale of Goods Act*, RSA 2000, c. S-2; *Sale of Goods Act*, RSS 1978, c. S-1; *The Sale of Goods Act*, CCSM 2000, c. S10; *Sale of Goods Act*, RSO 1990, c. S.1; *Sale of Goods Act*, RSNL 1990, c. S-6 ;*Sale of Goods Act*, RSNS 1989, c. 408; *Sale of Goods Act*, RSNB 2016, c. 110; *Sale of Goods Act*, RSPEI 1988, c. S-1; *Sale of Goods Act*, RSY 2002, c. 198; *Sale of Goods Act*, RSNWT 1988, c. S-2; and *Sale of Goods Act*, RSNWT (Nu) 1988, c. S-2
5. *Motor Vehicle Safety Act* , R.S.C. 1993, c.16, *Motor Vehicle Safety Regulations, C.R.C. c.1038*
6. 49 U.S. Code 301 - *Motor Vehicle Safety Act*
7. *Canadian Environmental Protection Act*, 1999 S.C. 1999. c.33
8. *Court Order Interest Act*, R.S.B.C., c. 79
9. *Competition Act*, R.S.C 1985, c. C-34
10. *Limitation Act*, S.B.C. 2012, c.13; *Limitations Act*, RSA 2000, c. L-12; *The Limitations Act*, SS 2004, c. L-16.1; *The Limitations Act*, SS 2004, c. L-16.1; *The Limitation of Actions Act*, CCSM c. L150; *Limitations Act*, 2002, SO 2002, c. 24, Sch. B; *Limitations Act*, SNL 1995, c. L-16.1; *Limitation of Actions Act*, SNS 2014, c. 35; *Limitation of Actions Act*, SNB 2009, c. L-8.5; *Statute of Limitations*, RSPEI 1988, c. S-7; *Limitation of Actions Act*, RSY 2002, c. 139; *Limitation of Actions Act*, RSNWT 1988, c. L-8; *Limitation of Actions Act*, RSNWT (Nu) 1988, c. L-8